

CERTIFICATE OF CONFORMITY



Equipment: Arm-based IoT Gateway System

Brand Name: Vecow

Test Model No.: AIC-110,
AIC-1XXXXXXXXXXXXXXXXX ("X" can be 0-9, A-Z
or blank for marketing purpose)



Applicant: Vecow Co., Ltd.

Test Report No.: LDBDBO-WTW-P22010294

We, **Bureau Veritas Consumer Products Services (Hong Kong) Limited, Taoyuan Branch, Lin Kou Laboratories**, declare that the equipment above has been tested in our facility and found compliance with the requirement limits of applicable standards, in accordance with the Directive 2014/35/EU. The test record, data evaluation and Equipment Under Test (EUT) configurations represented herein are true and accurate under the standards herein specified.

EN 62368-1:2014+A11:2017

Edward Chiueh / Technical Manager
2022-06-13





Test Report No.: LDBDBO-WTW-P22010294

Client

Name : **Vecow Co., Ltd.**
Address : **3F., No.10, Jiankang Rd., Zhonghe Dist., New Taipei City 23586, Taiwan**

Test Item : **Arm-based IoT Gateway System**

Identification : **AIC-110, AIC-1XXXXXXXXXXXXXXXXX ("X" can be 0-9, A-Z or blank for marketing purpose)**

Testing laboratory

Name : **Bureau Veritas Consumer Products Services (Hong Kong) Limited, Taoyuan Branch, Lin Kou Laboratories**
Address : **No. 47-2, 14th Ling, Chia Pau Vil., Lin Kou Dist., New Taipei City, Taiwan**

Test specification

Standard : **EN 62368-1:2014/A11:2017**

Test Result : The test item passed.

Prepared By :

Ryder Chang

2022-06-13

Date

Signature

Ryder Chang

Project Handler

Approved By:

Bill Lin

2022-06-13

Date

Signature

Bill Lin

Reviewer

This report should not be used by the client to claim product certification, approval, or endorsement by TAF, NVLAP, NIST or any government agencies.



This report is for your exclusive use. Any copying or replication of this report to or for any other person or entity, or use of our name or trademark, is permitted only with our prior written permission. This report sets forth our findings solely with respect to the test samples identified herein. The results set forth in this report are not indicative or representative of the quality or characteristics of the lot from which a test sample was taken or any similar or identical product unless specifically and expressly noted. Our report includes all of the tests requested by you and the results thereof based upon the information that you provided to us. You have 60 days from date of issuance of this report to notify us of any material error or omission caused by our negligence, provided, however, that such notice shall be in writing and shall specifically address the issue you wish to raise. A failure to raise such issue within the prescribed time shall constitute your unqualified acceptance of the completeness of this report, the tests conducted and the correctness of the report contents. In this report, the measurement uncertainty is not included for the decision rule of the conformity assessment.



TEST REPORT
EN 62368-1
Audio/video, information and communication technology equipment - Safety -
Part 1: Safety requirements

Report	
Reference No.	LDBDBO-WTW-P22010294
Compiled by (+ signature)	See cover sheet
Approved by (+ signature)	See cover sheet
Date of issue	2022-06-13
Total number of pages	70

Testing laboratory	
Name	Bureau Veritas Consumer Products Services (Hong Kong) Limited, Taoyuan Branch, Lin Kou Laboratories
Address	No. 47-2, 14th Ling, Chia Pau Vil., Lin Kou Dist., New Taipei City, Taiwan
Testing location	Bureau Veritas Consumer Products Services (Hong Kong) Limited, Taoyuan Branch, Lin Kou Laboratories
Address	No.19, Hwa Ya 2nd Rd., Wen Hwa Vil., Kwei Shan Dist., Taoyuan City, Taiwan

Client	
Name	Vecow Co., Ltd.
Address	3F., No.10, Jiankang Rd., Zhonghe Dist., New Taipei City 23586, Taiwan

Test specification	
Standard	EN 62368-1:2014/A11:2017
Test procedure	CE Marking service in LVD
Non-standard test method	N/A

Test Report Form No.	IEC62368_1B
Test Report Form(s) Originator	UL(US)
Master TRF	2014-03

Test item	
Description	Arm-based IoT Gateway System
Trademark	Vecow
Model and/or type reference	AIC-110, AIC-1XXXXXXXXXXXXXXXXX ("X" can be 0-9, A-Z or blank for marketing purpose)
Manufacturer	Vecow Co., Ltd.
Rating(s)	Supplied by External DC power source (For Terminal Block) DC 9-50V, 4A



Copy of marking plate and summary of test results (information/comments):

Input Rating: 9 - 50V  4A

Model:AIC-110

TYPE: Arm-based IoT Gateway System

Serial No : 
AC22A000004

Manufacturers: Vecow Co., Ltd.

This device complies with Part 15 of the FCC Rules. Operation is subject to the following two conditions : (1) this device may not cause harmful interface, and (2) the device must accept any interface received. including interface that may cause undesires operation.



 WARNING:
HOT SURFACE.
DO NOT TOUCH



Made In Taiwan



TEST ITEM PARTICULARS:	
Classification of use by	<input type="checkbox"/> Ordinary person <input checked="" type="checkbox"/> Instructed person <input checked="" type="checkbox"/> Skilled person <input type="checkbox"/> Children likely to be present
Supply Connection.....	<input type="checkbox"/> AC Mains <input type="checkbox"/> DC Mains <input checked="" type="checkbox"/> External Circuit - not Mains connected - <input checked="" type="checkbox"/> ES1 <input type="checkbox"/> ES2 <input type="checkbox"/> ES3
Supply % Tolerance	<input type="checkbox"/> +10%/-10% <input type="checkbox"/> +20%/-15% <input type="checkbox"/> +____%/ -____% <input checked="" type="checkbox"/> None
Supply Connection – Type	<input type="checkbox"/> pluggable equipment type A - <input type="checkbox"/> non-detachable supply cord <input type="checkbox"/> appliance coupler <input type="checkbox"/> direct plug-in <input type="checkbox"/> mating connector <input type="checkbox"/> pluggable equipment type B - <input type="checkbox"/> non-detachable supply cord <input type="checkbox"/> appliance coupler <input type="checkbox"/> permanent connection <input checked="" type="checkbox"/> mating connector <input checked="" type="checkbox"/> other: DC supply
Considered current rating of protective device as part of building or equipment installation	_____ A; Installation location: <input type="checkbox"/> building; <input type="checkbox"/> equipment
Equipment mobility.....	<input checked="" type="checkbox"/> movable <input type="checkbox"/> hand-held <input type="checkbox"/> transportable <input type="checkbox"/> stationary <input type="checkbox"/> for building-in <input type="checkbox"/> direct plug-in <input type="checkbox"/> rack-mounting <input checked="" type="checkbox"/> wall-mounted
Over voltage category (OVC)	<input type="checkbox"/> OVC I <input type="checkbox"/> OVC II <input type="checkbox"/> OVC III <input type="checkbox"/> OVC IV <input checked="" type="checkbox"/> other: <u>Not directly connected to mains</u>
Class of equipment	<input type="checkbox"/> Class I <input type="checkbox"/> Class II <input checked="" type="checkbox"/> Class III
Access location	<input type="checkbox"/> restricted access location <input checked="" type="checkbox"/> N/A
Pollution degree (PD)	<input type="checkbox"/> PD 1 <input checked="" type="checkbox"/> PD 2 <input type="checkbox"/> PD 3
Manufacturer's specified maximum operating ambient:	55°C
IP protection class	<input checked="" type="checkbox"/> IPX0 <input type="checkbox"/> IP____
Power Systems	<input type="checkbox"/> TN <input type="checkbox"/> TT <input type="checkbox"/> IT - _____ V L-L
Altitude during operation (m)	<input checked="" type="checkbox"/> 2000 m or less <input type="checkbox"/> _____ m
Altitude of test laboratory (m)	<input checked="" type="checkbox"/> 2000 m or less <input type="checkbox"/> _____ m
Mass of equipment (kg)	<input checked="" type="checkbox"/> 0.4 kg



POSSIBLE TEST CASE VERDICTS:	
- test case does not apply to the test object.....:	N/A
- test object does meet the requirement.....:	P (Pass)
- test object does not meet the requirement	F (Fail)
TESTING:	
Date of receipt of test item	2022-04-29
Date (s) of performance of tests	2022-05-16 to 2022-05-25
GENERAL REMARKS:	
<p>"(See Enclosure #)" refers to additional information appended to the report. "(See appended table)" refers to a table appended to the report.</p> <p>Throughout this report a <input type="checkbox"/> comma / <input checked="" type="checkbox"/> point is used as the decimal separator.</p>	
GENERAL PRODUCT INFORMATION:	
<p>Product Description – The equipment is a Gateway system which is intended to be used with information technology equipment covered by the scope of this standard.</p>	
<p>Model Differences – All models are identical to each other except for model designation for different marketing.</p>	
<p>Additional application considerations – (Considerations used to test a component or sub-assembly) –</p> <ol style="list-style-type: none"> 1) Dimension of EUT (Unit mm): 91 by 91 by 47. 2) The mouse enclosures are secured by screw. 3) All the outputs except output of USB port (male type), there have been evaluated and found to comply with Limited Power Source. 4) For all power sources' output rating shall be (9-50Vdc, 4A min.) for Terminal Block, with maximum operation temperature 55°C min. and its output shall comply with the requirement of SELV for IEC 60950-1 or ES1 for IEC 62368-1 and in compliance with the requirements of Limited power source of IEC 60950-1 and IEC 62368-1. 	
<p>Test condition: Temperature: 25°C Relative humidity: 60% Air pressure: 950 mbar</p>	
<p>The test sample was a pre-production sample without serial number.</p>	



ENERGY SOURCE IDENTIFICATION AND CLASSIFICATION TABLE:	
<p>(Note 1: Identify the following six (6) energy source forms based on the origin of the energy.) (Note 2: The identified classification e.g., ES2, TS1, should be with respect to its ability to cause pain or injury on the body or its ability to ignite a combustible material. Any energy source can be declared Class 3 as a worse case classification e.g. PS3, ES3.)</p>	
<p>Electrically-caused injury (Clause 5): (Note: Identify type of source, list sub-assembly or circuit designation and corresponding energy source classification) Example: +5 V dc input ES1</p>	
Source of electrical energy	Corresponding classification (ES)
Supplied by External DC power source (9 – 50Vdc) (For Terminal Block)	ES1
Internal circuits	ES1
All output port	ES1
<p>Electrically-caused fire (Clause 6): (Note: List sub-assembly or circuit designation and corresponding energy source classification) Example: Battery pack (maximum 85 watts): PS2</p>	
Source of power or PIS	Corresponding classification (PS)
Supplied by External DC power source (For Terminal Block)	PS2
Internal circuits	PS1
All output port	PS1
<p>Injury caused by hazardous substances (Clause 7) (Note: Specify hazardous chemicals, whether produces ozone or other chemical construction not addressed as part of the component evaluation.) Example: Liquid in filled component Glycol</p>	
Source of hazardous substances	Corresponding chemical
--	--
<p>Mechanically-caused injury (Clause 8) (Note: List moving part(s), fan, special installations, etc. & corresponding MS classification based on Table 35.) Example: Wall mount unit MS2</p>	
Source of kinetic/mechanical energy	Corresponding classification (MS)
Equipment mass	MS1
Edges and corners are round not sharp	MS1
Wall mount (more than 2 m height)	MS3
<p>Thermal burn injury (Clause 9) (Note: Identify the surface or support, and corresponding energy source classification based on type of part, location, operating temperature and contact time in Table 38.) Example: Hand-held scanner – thermoplastic enclosure TS1</p>	
Source of thermal energy	Corresponding classification (TS)
Accessible parts	TS1



ENERGY SOURCE IDENTIFICATION AND CLASSIFICATION TABLE:	
Radiation (Clause 10) (Note: List the types of radiation present in the product and the corresponding energy source classification.) Example: DVD – Class 1 Laser Product RS1	
Type of radiation	Corresponding classification (RS)
LED Indicators	RS1



ENERGY SOURCE DIAGRAM

Indicate which energy sources are included in the energy source diagram. Insert diagram below

■ ES ■ PS ■ MS ■ TS ■ RS

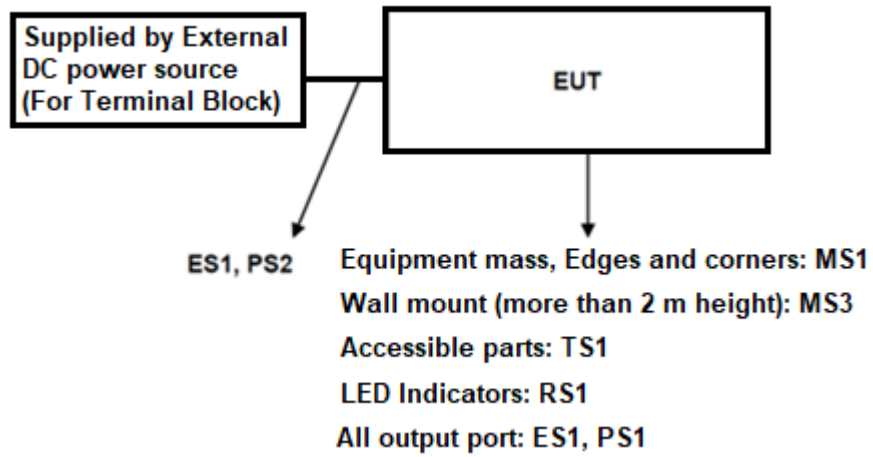



OVERVIEW OF EMPLOYED SAFEGUARDS				
Clause	Possible Hazard			
5.1	Electrically-caused injury			
Body Part (e.g. Ordinary)	Energy Source (ES3: Primary Filter circuit)	Safeguards		
		Basic	Supplementary	Reinforced (Enclosure)
Instructed person and Skilled person	ES1: Supplied by External DC power source (12 – 48Vdc) (For Terminal Block)	N/A	N/A	N/A
Instructed person and Skilled person	ES1: Internal circuits	N/A	N/A	N/A
Instructed person and Skilled person	ES1: All output port	N/A	N/A	N/A
6.1	Electrically-caused fire			
Material part (e.g. mouse enclosure)	Energy Source (PS2: 100 Watt circuit)	Safeguards		
		Basic	Supplementary	Reinforced
Internal Circuits/Components	PS2: Supplied by External DC power source (For Terminal Block)	Not overheat	Suitable material	N/A
Internal Wiring	PS2: Internal circuits	Not overheat	Suitable material	N/A
Output port	PS1: All output port	N/A	See appended 6.2.2	N/A
7.1	Injury caused by hazardous substances			
Body Part (e.g., skilled)	Energy Source (hazardous material)	Safeguards		
		Basic	Supplementary	Reinforced
--	--	--	--	--
8.1	Mechanically-caused injury			
Body Part (e.g. Ordinary)	Energy Source (MS3:High Pressure Lamp)	Safeguards		
		Basic	Supplementary	Reinforced (Enclosure)
Instructed person and Skilled person	MS1: Equipment Mass	N/A	N/A	N/A
Instructed person and Skilled person	MS1: Edges and corners are round not sharp	N/A	N/A	N/A
Instructed person and Skilled person	MS3: Wall mount (More than 2m height)	N/A	N/A	Refer to clause 8.7.
9.1	Thermal Burn			
Body Part (e.g., Ordinary)	Energy Source (TS2)	Safeguards		
		Basic	Supplementary	Reinforced
Instructed person and Skilled person	TS1: Accessible parts	N/A	N/A	N/A
10.1	Radiation			



Body Part (e.g., Ordinary)	Energy Source (Output from audio port)	Safeguards		
		Basic	Supplementary	Reinforced
Instructed person and Skilled person	RS1: LED Indicators	N/A	N/A	N/A
Supplementary Information: (1) See attached energy source diagram for additional details. (2) "N" – Normal Condition; "A" – Abnormal Condition; "S" Single Fault				



EN 62368-1			
Clause	Requirement + Test	Result - Remark	Verdict
4	GENERAL REQUIREMENTS		P
4.1.1	Acceptance of materials, components and subassemblies	Materials, components and subassemblies, which were found to affect safety aspects, are conformed to the relevant IEC component standards and/or comply with the requirements of this standard. Components and subassemblies that comply with IEC 60950-1 or IEC 60065 are acceptable as part of equipment covered by this standard without further evaluation other than to give consideration to the appropriate use of the component or subassembly in the end-product.	P
4.1.2	Use of components	Components comply with the requirements of this standard or, where specified in a requirements clause, with the safety aspects of the relevant IEC component standards. (See appended table 4.1.2)	P
4.1.3	Equipment design and construction	Equipment designed and constructed that, under normal operating conditions (see Clause B.2) and single fault conditions (see Clause B.4), safeguards are provided to reduce the likelihood of injury or, in the case of fire, property damage. Parts of equipment that could cause injury are not be accessible, and accessible parts are not cause an injury.	P
4.1.15	Markings and instructions.....:	Markings and instructions meet the relevant requirements of Annex F. (See Annex F)	P
4.4.4	Safeguard robustness	See below	P
4.4.4.2	Steady force tests.....:	(See Annex T.2)	P
4.4.4.3	Drop tests.....:		N/A
4.4.4.4	Impact tests.....:		N/A
4.4.4.5	Internal accessible safeguard enclosure and barrier tests.....:		N/A
4.4.4.6	Glass Impact tests.....:		N/A
4.4.4.7	Thermoplastic material tests.....:		N/A



EN 62368-1			
Clause	Requirement + Test	Result - Remark	Verdict
4.4.4.8	Air comprising a safeguard.....:		N/A
4.4.4.9	Accessibility and safeguard effectiveness	After test, all safeguards still remain effective.	P
4.5	Explosion	(See Annex M)	P
4.6	Fixing of conductors	See below.	P
4.6.1	Fix conductors not to defeat a safeguard	Considered.	P
4.6.2	10 N force test applied to	Conductors connected by soldering and held in place near to the termination.	P
4.7	Equipment for direct insertion into mains socket - outlets	Not such construction.	N/A
4.7.2	Mains plug part complies with the relevant standard.....:		N/A
4.7.3	Torque (Nm)		N/A
4.8	Products containing coin/button cell batteries	No battery compartment door / cover for RTC battery. This RTC battery is inside the EUT and need tool to open EUT for replacement during servicing.	N/A
4.8.2	Instructional safeguard		N/A
4.8.3	Battery Compartment Construction	No such component.	N/A
	Means to reduce the possibility of children removing the battery.....:		—
4.8.4	Battery Compartment Mechanical Tests	No such component.	N/A
4.8.5	Battery Accessibility	No such component.	N/A
4.9	Likelihood of fire or shock due to entry of conductive object.....:		N/A
5	ELECTRICALLY-CAUSED INJURY		P
5.2.1	Electrical energy source classifications	See below.	P
5.2.2	ES1, ES2 and ES3 limits	See Energy source identification and classification table.	P
5.2.2.2	Steady-state voltage and current		P
5.2.2.3	Capacitance limits.....:		N/A
5.2.2.4	Single pulse limits		N/A
5.2.2.5	Limits for repetitive pulses		N/A
5.2.2.6	Ringing signals		N/A
5.2.2.7	Audio signals		N/A
5.3	Protection against electrical energy sources	See below.	P
5.3.1	General Requirements for accessible parts to ordinary, instructed and skilled persons	Only ES1 circuits.	P



EN 62368-1			
Clause	Requirement + Test	Result - Remark	Verdict
5.3.2.1	Accessibility to electrical energy sources and safeguards	Only ES1 circuits.	P
5.3.2.2	Contact requirements	Only ES1 circuits.	N/A
	a) Test with test probe from Annex V..... :		N/A
	b) Electric strength test potential (V)..... :		N/A
	c) Air gap (mm) :		N/A
5.3.2.4	Terminals for connecting stripped wire	No such construction.	N/A
5.4	Insulation materials and requirements		N/A
5.4.1.2	Properties of insulating material	Only ES1 circuits.	N/A
5.4.1.3	Humidity conditioning..... :		N/A
5.4.1.4	Maximum operating temperature for insulating materials..... :		N/A
5.4.1.5	Pollution degree..... :	Pollution degree 2.	—
5.4.1.5.2	Test for pollution degree 1 environment and for an insulating compound		N/A
5.4.1.5.3	Thermal cycling		N/A
5.4.1.6	Insulation in transformers with varying dimensions		N/A
5.4.1.7	Insulation in circuits generating starting pulses		N/A
5.4.1.8	Determination of working voltage		N/A
5.4.1.9	Insulating surfaces		N/A
5.4.1.10	Thermoplastic parts on which conductive metallic parts are directly mounted		N/A
5.4.1.10.2	Vicat softening temperature..... :		N/A
5.4.1.10.3	Ball pressure..... :		N/A
5.4.2	Clearances		N/A
5.4.2.2	Determining clearance using peak working voltage		N/A
5.4.2.3	Determining clearance using required withstand voltage..... :		N/A
	a) a.c. mains transient voltage..... :		—
	b) d.c. mains transient voltage..... :		—
	c) external circuit transient voltage..... :		—
	d) transient voltage determined by measurement . :		—
5.4.2.4	Determining the adequacy of a clearance using an electric strength test		N/A
5.4.2.5	Multiplication factors for clearances and test voltages..... :		N/A
5.4.3	Creepage distances..... :		N/A
5.4.3.1	General		N/A
5.4.3.3	Material Group..... :		—



EN 62368-1			
Clause	Requirement + Test	Result - Remark	Verdict
5.4.4	Solid insulation		N/A
5.4.4.2	Minimum distance through insulation :		N/A
5.4.4.3	Insulation compound forming solid insulation		N/A
5.4.4.4	Solid insulation in semiconductor devices		N/A
5.4.4.5	Cemented joints		N/A
5.4.4.6	Thin sheet material		N/A
5.4.4.6.1	General requirements		N/A
5.4.4.6.2	Separable thin sheet material		N/A
	Number of layers (pcs) :		N/A
5.4.4.6.3	Non-separable thin sheet material		N/A
5.4.4.6.4	Standard test procedure for non-separable thin sheet material :		N/A
5.4.4.6.5	Mandrel test		N/A
5.4.4.7	Solid insulation in wound components		N/A
5.4.4.9	Solid insulation at frequencies >30 kHz :		N/A
5.4.5	Antenna terminal insulation	No such construction.	N/A
5.4.5.1	General		N/A
5.4.5.2	Voltage surge test		N/A
	Insulation resistance (MΩ)..... :		—
5.4.6	Insulation of internal wire as part of supplementary safeguard :		N/A
5.4.7	Tests for semiconductor components and for cemented joints		N/A
5.4.8	Humidity conditioning	No critical insulation.	N/A
	Relative humidity (%)..... :		—
	Temperature (°C) :		—
	Duration (h) :		—
5.4.9	Electric strength test :		N/A
5.4.9.1	Test procedure for a solid insulation type test		N/A
5.4.9.2	Test procedure for routine tests		N/A
5.4.10	Protection against transient voltages between external circuit	No such construction.	N/A
5.4.10.1	Parts and circuits separated from external circuits		N/A
5.4.10.2	Test methods		N/A
5.4.10.2.1	General		N/A
5.4.10.2.2	Impulse test :		N/A
5.4.10.2.3	Steady-state test..... :		N/A



EN 62368-1			
Clause	Requirement + Test	Result - Remark	Verdict
5.4.11	Insulation between external circuits and earthed circuitry		N/A
5.4.11.1	Exceptions to separation between external circuits and earth		N/A
5.4.11.2	Requirements		N/A
	Rated operating voltage U_{op} (V).....		—
	Nominal voltage U_{peak} (V).....		—
	Max increase due to variation U_{sp}		—
	Max increase due to ageing ΔU_{sa}		—
	$U_{op} = U_{peak} + \Delta U_{sp} + \Delta U_{sa}$		—
5.5	Components as safeguards		
5.5.1	General	Only ES1 circuits.	N/A
5.5.2	Capacitors and RC units		N/A
5.5.2.1	General requirement		N/A
5.5.2.2	Safeguards against capacitor discharge after disconnection of a connector.....		N/A
5.5.3	Transformers		N/A
5.5.4	Optocouplers		N/A
5.5.5	Relays		N/A
5.5.6	Resistors		N/A
5.5.7	SPD's		N/A
5.5.7.1	Use of an SPD connected to reliable earthing		N/A
5.5.7.2	Use of an SPD between mains and protective earth		N/A
5.5.8	Insulation between the mains and external circuit consisting of a coaxial cable.....		N/A
5.6	Protective conductor		N/A
5.6.2	Requirement for protective conductors	Only ES1 circuits.	N/A
5.6.2.1	General requirements		N/A
5.6.2.2	Colour of insulation		N/A
5.6.3	Requirement for protective earthing conductors		N/A
	Protective earthing conductor size (mm ²)		—
5.6.4	Requirement for protective bonding conductors		N/A
5.6.4.1	Protective bonding conductors		N/A
	Protective bonding conductor size (mm ²).		—
	Protective current rating (A)		—
5.6.4.3	Current limiting and overcurrent protective devices		N/A



EN 62368-1			
Clause	Requirement + Test	Result - Remark	Verdict
5.6.5	Terminals for protective conductors		N/A
5.6.5.1	Requirement		N/A
	Conductor size (mm ²), nominal thread diameter (mm)		N/A
5.6.5.2	Corrosion		N/A
5.6.6	Resistance of the protective system		N/A
5.6.6.1	Requirements		N/A
5.6.6.2	Test Method Resistance (Ω).....		N/A
5.6.7	Reliable earthing		N/A
5.7	Prospective touch voltage, touch current and protective conductor current		N/A
5.7.2	Measuring devices and networks	Only ES1 circuits.	N/A
5.7.2.1	Measurement of touch current		N/A
5.7.2.2	Measurement of prospective touch voltage		N/A
5.7.3	Equipment set-up, supply connections and earth connections		N/A
	System of interconnected equipment (separate connections/single connection)		—
	Multiple connections to mains (one connection at a time/simultaneous connections)		—
5.7.4	Earthed conductive accessible parts		N/A
5.7.5	Protective conductor current		N/A
	Supply Voltage (V).....		—
	Measured current (mA).....		—
	Instructional Safeguard.....		N/A
5.7.6	Prospective touch voltage and touch current due to external circuits		N/A
5.7.6.1	Touch current from coaxial cables		N/A
5.7.6.2	Prospective touch voltage and touch current from external circuits		N/A
5.7.7	Summation of touch currents from external circuits		N/A
	a) Equipment with earthed external circuits Measured current (mA).....		N/A
	b) Equipment whose external circuits are not referenced to earth. Measured current (mA)		N/A
6	ELECTRICALLY- CAUSED FIRE		P
6.2	Classification of power sources (PS) and potential ignition sources (PIS)		P
6.2.2	Power source circuit classifications	See Energy source identification and classification table.	P



EN 62368-1			
Clause	Requirement + Test	Result - Remark	Verdict
6.2.2.1	General	See below.	P
6.2.2.2	Power measurement for worst-case load fault ... :		N/A
6.2.2.3	Power measurement for worst-case power source fault..... :		N/A
6.2.2.4	PS1	(See appended table 6.2.2)	P
6.2.2.5	PS2	Supplied by External DC power source.	P
6.2.2.6	PS3	No PS3 parts	N/A
6.2.3	Classification of potential ignition sources	See below.	P
6.2.3.1	Arcing PIS	All internal circuits are considered not arcing PIS for they are supplied by external power supply whose open voltage is less than 50V.	N/A
6.2.3.2	Resistive PIS	(See appended table 6.2.3.2)	P
6.3	Safeguards against fire under normal operating conditions and abnormal operating conditions		P
6.3.1 (a)	No ignition and attainable temperature value less than 90 % defined by ISO 871 or less than 300 °C for unknown materials	(See appended table 5.4.1.5, 6.3.2, 9.0, B.2.6)	P
6.3.1 (b)	Combustible materials outside fire enclosure	No fire enclosure or fire barrier was needed.	N/A
6.4	Safeguards against fire under single fault conditions		P
6.4.1	Safeguard Method	Method by control of fire spread applied. See 6.4.4, 6.4.5 and 6.4.6.	P
6.4.2	Reduction of the likelihood of ignition under single fault conditions in PS1 circuits	Not applicable. See 6.4.1.	N/A
6.4.3	Reduction of the likelihood of ignition under single fault conditions in PS2 and PS3 circuits	Not applicable. See 6.4.1.	N/A
6.4.3.1	General		N/A
6.4.3.2	Supplementary Safeguards		N/A
	Special conditions if conductors on printed boards are opened or peeled		N/A
6.4.3.3	Single Fault Conditions..... :		N/A
	Special conditions for temperature limited by fuse		N/A
6.4.4	Control of fire spread in PS1 circuits		N/A
6.4.5	Control of fire spread in PS2 circuits	Supplied by External DC power source.	P



EN 62368-1			
Clause	Requirement + Test	Result - Remark	Verdict
6.4.5.2	Supplementary safeguards	<ul style="list-style-type: none"> - Printed board is rated min. V-1. - All components and combustible materials other than small parts are either rated at least V-2 or mounted on material with rating min. V-1. - Wire insulation and tubing shall comply with IEC 60332-1-2, IEC 60332-1-3, IEC 60332-2-2 or IEC/TS 60695-11-21. 	P
6.4.6	Control of fire spread in PS3 circuit	No PS3 circuit.	N/A
6.4.7	Separation of combustible materials from a PIS	No fire enclosure or fire barrier required.	N/A
6.4.7.1	General		N/A
6.4.7.2	Separation by distance		N/A
6.4.7.3	Separation by a fire barrier		N/A
6.4.8	Fire enclosures and fire barriers	No fire enclosure or fire barrier was needed.	N/A
6.4.8.1	Fire enclosure and fire barrier material properties		N/A
6.4.8.2.1	Requirements for a fire barrier		N/A
6.4.8.2.2	Requirements for a fire enclosure		N/A
6.4.8.3	Constructional requirements for a fire enclosure and a fire barrier		N/A
6.4.8.3.1	Fire enclosure and fire barrier openings	No fire enclosure or fire barrier was needed.	N/A
6.4.8.3.2	Fire barrier dimensions		N/A
6.4.8.3.3	Top Openings in Fire Enclosure: dimensions (mm)	No openings.	N/A
	Needle Flame test		N/A
6.4.8.3.4	Bottom Openings in Fire Enclosure, condition met a), b) and/or c) dimensions (mm)	No openings.	N/A
	Flammability tests for the bottom of a fire enclosure		N/A
6.4.8.3.5	Integrity of the fire enclosure, condition met: a), b) or c)		N/A
6.4.8.4	Separation of PIS from fire enclosure and fire barrier distance (mm) or flammability rating		N/A
6.5	Internal and external wiring		P
6.5.1	Requirements	The used wiring comply with the requirement of IEC 60332 and IEC/TS 60695-11-21 with rated VW-1/FT-1.	P
6.5.2	Cross-sectional area (mm ²)		—



EN 62368-1			
Clause	Requirement + Test	Result - Remark	Verdict
6.5.3	Requirements for interconnection to building wiring		N/A
6.6	Safeguards against fire due to connection to additional equipment	See below.	P
	External port limited to PS2 or complies with Clause Q.1	Output connectors comply with PS2.	P

7	INJURY CAUSED BY HAZARDOUS SUBSTANCES		N/A
7.2	Reduction of exposure to hazardous substances	No hazardous substances.	N/A
7.3	Ozone exposure		N/A
7.4	Use of personal safeguards (PPE)		N/A
	Personal safeguards and instructions		—
7.5	Use of instructional safeguards and instructions		N/A
	Instructional safeguard (ISO 7010)		—
7.6	Batteries		N/A

8	MECHANICALLY-CAUSED INJURY		P
8.1	General	See below.	P
8.2	Mechanical energy source classifications	See Energy source identification and classification table.	P
8.3	Safeguards against mechanical energy sources	See Overview of employed safeguards.	P
8.4	Safeguards against parts with sharp edges and corners	Accessible edges and corners of the equipment are rounded and are classified as MS1.	P
8.4.1	Safeguards	Edges and corners of the enclosure are rounded.	N/A
8.5	Safeguards against moving parts	No such construction.	N/A
8.5.1	MS2 or MS3 part required to be accessible for the function of the equipment		N/A
8.5.2	Instructional Safeguard..... :		—
8.5.4	Special categories of equipment comprising moving parts	No such construction.	N/A
8.5.4.1	Large data storage equipment		N/A
8.5.4.2	Equipment having electromechanical device for destruction of media		N/A
8.5.4.2.1	Safeguards and Safety Interlocks		N/A
8.5.4.2.2	Instructional safeguards against moving parts		N/A
	Instructional Safeguard..... :		—
8.5.4.2.3	Disconnection from the supply		N/A



EN 62368-1			
Clause	Requirement + Test	Result - Remark	Verdict
8.5.4.2.4	Probe type and force (N)		N/A
8.5.5	High Pressure Lamps	No such construction.	N/A
8.5.5.1	Energy Source Classification		N/A
8.5.5.2	High Pressure Lamp Explosion Test		N/A
8.6	Stability	Equipment mass is MS1.	N/A
8.6.1	Product classification		N/A
	Instructional Safeguard.....		—
8.6.2	Static stability		N/A
8.6.2.2	Static stability test		N/A
	Applied Force		—
8.6.2.3	Downward Force Test		N/A
8.6.3	Relocation stability test		N/A
	Unit configuration during 10° tilt		—
8.6.4	Glass slide test		N/A
8.6.5	Horizontal force test (Applied Force)		N/A
	Position of feet or movable parts.....		—
8.7	Equipment mounted to wall or ceiling	See below	P
8.7.1	Mounting Means (Length of screws (mm) and mounting surface)	According to the installation, the EUT can be mounted on the wall by screws (specification: M3 x 4L). And mounting surface of EUT is metal.	P



EN 62368-1			
Clause	Requirement + Test	Result - Remark	Verdict
8.7.2	Direction and applied force..... :	Method 2 used, Test force: 4N (0.4kg x 4 times x 9.8/4 = 3.92N); 1) Each point in the mounting system subjected to a shear force perpendicular to its centre axis for 1 min. The force applied in four directions, one direction at a time, separated by 90°. 2) Each point in the mounting system, one at a time, subjected to an inward directed push force parallel to its centre axis for 1 min. 3) Each point in the mounting system, one at a time, subjected to an outward directed pull force parallel to its centre axis for 1 min. And the equipment or its associated mounting means not become dislodged and remain mechanically intact and secure during the test.	P
8.8	Handles strength	No handles.	N/A
8.8.1	Classification		N/A
8.8.2	Applied Force :		N/A
8.9	Wheels or casters attachment requirements	No wheels or casters.	N/A
8.9.1	Classification		N/A
8.9.2	Applied force :		—
8.10	Carts, stands and similar carriers	No carts, stands and similar carriers.	N/A
8.10.1	General		N/A
8.10.2	Marking and instructions		N/A
	Instructional Safeguard..... :		—
8.10.3	Cart, stand or carrier loading test and compliance		N/A
	Applied force :		—
8.10.4	Cart, stand or carrier impact test		N/A
8.10.5	Mechanical stability		N/A
	Applied horizontal force (N) :		—
8.10.6	Thermoplastic temperature stability (°C) :		N/A
8.11	Mounting means for rack mounted equipment	Not for rack mounting.	N/A
8.11.1	General		N/A
8.11.2	Product Classification		N/A



EN 62368-1			
Clause	Requirement + Test	Result - Remark	Verdict
8.11.3	Mechanical strength test, variable <i>N</i>		N/A
8.11.4	Mechanical strength test 250N, including end stops		N/A
8.12	Telescoping or rod antennas.....	No telescoping or rod antennas.	N/A
	Button/Ball diameter (mm).....		—

9	THERMAL BURN INJURY		P
9.2	Thermal energy source classifications	TS1: Enclosure surface.	P
9.3	Safeguard against thermal energy sources	No safeguard is required.	N/A
9.4	Requirements for safeguards		N/A
9.4.1	Equipment safeguard		N/A
9.4.2	Instructional safeguard		N/A

10	RADIATION		P
10.2	Radiation energy source classification	See below.	P
10.2.1	General classification	See Energy source identification and classification table.	P
10.3	Protection against laser radiation	No laser radiation.	N/A
	Laser radiation that exists equipment:		—
	Normal, abnormal, single-fault.....		N/A
	Instructional safeguard		—
	Tool.....		—
10.4	Protection against visible, infrared, and UV radiation	No visible, infrared, and UV radiation.	N/A
10.4.1	General		N/A
10.4.1.a)	RS3 for Ordinary and instructed persons		N/A
10.4.1.b)	RS3 accessible to a skilled person.....		N/A
	Personal safeguard (PPE) instructional safeguard.....		—
10.4.1.c)	Equipment visible, IR, UV does not exceed RS1 . :		N/A
10.4.1.d)	Normal, abnormal, single-fault conditions		N/A
10.4.1.e)	Enclosure material employed as safeguard is opaque.....		N/A
10.4.1.f)	UV attenuation		N/A
10.4.1.g)	Materials resistant to degradation UV		N/A
10.4.1.h)	Enclosure containment of optical radiation.....		N/A
10.4.1.i)	Exempt Group under normal operating conditions		N/A
10.4.2	Instructional safeguard		N/A



EN 62368-1			
Clause	Requirement + Test	Result - Remark	Verdict
10.5	Protection against x-radiation	No x-radiation.	N/A
10.5.1	X- radiation energy source that exists equipment:		N/A
	Normal, abnormal, single fault conditions		N/A
	Equipment safeguards..... :		N/A
	Instructional safeguard for skilled person :		N/A
10.5.3	Most unfavourable supply voltage to give maximum radiation :		—
	Abnormal and single-fault condition :		N/A
	Maximum radiation (pA/kg)..... :		N/A
10.6	Protection against acoustic energy sources	Not a personal music player.	N/A
10.6.1	General		N/A
10.6.2	Classification		N/A
	Acoustic output, dB(A) :		N/A
	Output voltage, unweighted r.m.s..... :		N/A
10.6.4	Protection of persons		N/A
	Instructional safeguards :		N/A
	Equipment safeguard prevent ordinary person to RS2..... :		—
	Means to actively inform user of increase sound pressure..... :		—
	Equipment safeguard prevent ordinary person to RS2 :		—
10.6.5	Requirements for listening devices (headphones, earphones, etc.)		N/A
10.6.5.1	Corded passive listening devices with analog input		N/A
	Input voltage with 94 dB(A) L_{Aeq} acoustic pressure output..... :		—
10.6.5.2	Corded listening devices with digital input		N/A
	Maximum dB(A) :		—
10.6.5.3	Cordless listening device		N/A
	Maximum dB(A) :		—

B	NORMAL OPERATING CONDITION TESTS, ABNORMAL OPERATING CONDITION TESTS AND SINGLE FAULT CONDITION TESTS		P
B.2	Normal Operating Conditions	See below.	P
B.2.1	General requirements..... :	(See Test Item Particulars and appended test tables)	P
	Audio Amplifiers and equipment with audio amplifiers :	No audio amplifiers.	N/A



EN 62368-1			
Clause	Requirement + Test	Result - Remark	Verdict
B.2.3	Supply voltage and tolerances	Not directly connected to mains. No tolerance is considered.	P
B.2.5	Input test..... :	(See appended table B.2.5)	P
B.3	Simulated abnormal operating conditions		P
B.3.1	General requirements..... :	See below.	P
B.3.2	Covering of ventilation openings	The unit was operated continuously under the Ventilation Openings Blocked.	N/A
B.3.3	D.C. mains polarity test	No such construction.	N/A
B.3.4	Setting of voltage selector :	No such construction.	N/A
B.3.5	Maximum load at output terminals :	(See appended table B.3)	P
B.3.6	Reverse battery polarity	No such construction.	N/A
B.3.7	Abnormal operating conditions as specified in Clause E.2.	No such construction.	N/A
B.3.8	Safeguards functional during and after abnormal operating conditions	During an abnormal operating condition that does not lead to a single fault condition, all safeguards shall remain effective. After restoration of normal operating conditions, all safeguards shall comply with applicable requirements.	P
B.4	Simulated single fault conditions		P
B.4.2	Temperature controlling device open or short-circuited :	No such construction.	N/A
B.4.3	Motor tests	No such construction.	N/A
B.4.3.1	Motor blocked or rotor locked increasing the internal ambient temperature :		N/A
B.4.4	Short circuit of functional insulation	Functional insulation failure will not cause defeat of safeguard.	P
B.4.4.1	Short circuit of clearances for functional insulation	(See appended table B.4)	P
B.4.4.2	Short circuit of creepage distances for functional insulation	(See appended table B.4)	P
B.4.4.3	Short circuit of functional insulation on coated printed boards	No such construction.	N/A
B.4.5	Short circuit and interruption of electrodes in tubes and semiconductors	No such construction.	N/A
B.4.6	Short circuit or disconnect of passive components	No such construction.	N/A
B.4.7	Continuous operation of components	No such construction.	N/A



EN 62368-1			
Clause	Requirement + Test	Result - Remark	Verdict
B.4.8	Class 1 and Class 2 energy sources within limits during and after single fault conditions	During and after single fault conditions, accessible parts does not exceed the relevant energy class and no flame and ignition inside the equipment.	P
B.4.9	Battery charging under single fault conditions.... :	No such construction.	N/A
C	UV RADIATION		N/A
C.1	Protection of materials in equipment from UV radiation	No UV radiation exposure.	N/A
C.1.2	Requirements		N/A
C.1.3	Test method		N/A
C.2	UV light conditioning test		N/A
C.2.1	Test apparatus		N/A
C.2.2	Mounting of test samples		N/A
C.2.3	Carbon-arc light-exposure apparatus		N/A
C.2.4	Xenon-arc light exposure apparatus		N/A
D	TEST GENERATORS		N/A
D.1	Impulse test generators	Not used.	N/A
D.2	Antenna interface test generator		N/A
D.3	Electronic pulse generator		N/A
E	TEST CONDITIONS FOR EQUIPMENT CONTAINING AUDIO AMPLIFIERS		N/A
E.1	Audio amplifier normal operating conditions		N/A
	Audio signal voltage (V).....:		—
	Rated load impedance (Ω)		—
E.2	Audio amplifier abnormal operating conditions		N/A
F	ANNEX F, EQUIPMENT MARKINGS, INSTRUCTIONS, AND INSTRUCTIONAL SAFEGUARDS		P
F.1	General requirements	See below.	P
	Instructions – Language	Safety related information in English has been evaluated. The language of the countries where the product will be distributed.	—
F.2	Letter symbols and graphical symbols	See below.	P
F.2.1	Letter symbols according to IEC60027-1	Not use.	N/A
F.2.2	Graphic symbols IEC, ISO or manufacturer specific	Considered.	P
F.3	Equipment markings		P
F.3.1	Equipment marking locations	On enclosure surface.	P
F.3.2	Equipment identification markings	See below.	P
F.3.2.1	Manufacturer identification	Trade mark: Vecow	—



EN 62368-1			
Clause	Requirement + Test	Result - Remark	Verdict
F.3.2.2	Model identification	AIC-110, AIC-1XXXXXXXXXXXXXXXXX ("X" can be 0-9, A-Z or blank for marketing purpose)	—
F.3.3	Equipment rating markings	See below.	P
F.3.3.1	Equipment with direct connection to mains	Not direct connection to mains.	N/A
F.3.3.2	Equipment without direct connection to mains	(See appended table B.2.5)	P
F.3.3.3	Nature of supply voltage	The DC symbol --- had been provided on the EUT's label according to IEC 60417, No. 5031.	—
F.3.3.4	Rated voltage	DC 9-50V	—
F.3.3.4	Rated frequency	DC only.	—
F.3.3.6	Rated current or rated power.....	4A	—
F.3.3.7	Equipment with multiple supply connections	No such construction.	N/A
F.3.4	Voltage setting device	No such construction.	N/A
F.3.5	Terminals and operating devices	No such construction.	N/A
F.3.5.1	Mains appliance outlet and socket-outlet markings		N/A
F.3.5.2	Switch position identification marking.....		N/A
F.3.5.3	Replacement fuse identification and rating markings	Class III equipment.	N/A
F.3.5.4	Replacement battery identification marking	No such construction.	N/A
F.3.5.5	Terminal marking location	No such construction.	N/A
F.3.6	Equipment markings related to equipment classification	Class III equipment.	N/A
F.3.6.1	Class I Equipment		N/A
F.3.6.1.1	Protective earthing conductor terminal		N/A
F.3.6.1.2	Neutral conductor terminal		N/A
F.3.6.1.3	Protective bonding conductor terminals		N/A
F.3.6.2	Class II equipment (IEC60417-5172)		N/A
F.3.6.2.1	Class II equipment with or without functional earth		N/A
F.3.6.2.2	Class II equipment with functional earth terminal marking		N/A
F.3.7	Equipment IP rating marking	No such construction.	—
F.3.8	External power supply output marking	Not apply for	N/A
F.3.9	Durability, legibility and permanence of marking	Complied.	P



EN 62368-1			
Clause	Requirement + Test	Result - Remark	Verdict
F.3.10	Test for permanence of markings	After this test there was no damage to the label. The marking on the label did not fade. There was no curling or lifting on the label edge.	P
F.4	Instructions		P
	a) Equipment for use in locations where children not likely to be present - marking	Considered.	P
	b) Instructions given for installation or initial use	Considered.	P
	c) Equipment intended to be fastened in place	Considered.	P
	d) Equipment intended for use only in restricted access area	Not apply for.	N/A
	e) Audio equipment terminals classified as ES3 and other equipment with terminals marked in accordance F.3.6.1	No such construction.	N/A
	f) Protective earthing employed as safeguard	Class III equipment.	N/A
	g) Protective earthing conductor current exceeding ES 2 limits	Class III equipment.	N/A
	h) Symbols used on equipment	No symbol used as an instructional safeguard.	N/A
	i) Permanently connected equipment not provided with all-pole mains switch	No such construction.	N/A
	j) Replaceable components or modules providing safeguard function	No such construction.	N/A
F.5	Instructional safeguards	See below.	P
	Where "instructional safeguard" is referenced in the test report it specifies the required elements, location of marking and/or instruction	Considered.	P
G	COMPONENTS		N/A
G.1	Switches		N/A
G.1.1	General requirements	Not use.	N/A
G.1.2	Ratings, endurance, spacing, maximum load		N/A
G.2	Relays		N/A
G.2.1	General requirements	Not use.	N/A
G.2.2	Overload test		N/A
G.2.3	Relay controlling connectors supply power		N/A
G.2.4	Mains relay, modified as stated in G.2		N/A
G.3	Protection Devices		N/A
G.3.1	Thermal cut-offs	Not use.	N/A
G.3.1.1a) &b)	Thermal cut-outs separately approved according to IEC 60730 with conditions indicated in a) & b)		N/A



EN 62368-1			
Clause	Requirement + Test	Result - Remark	Verdict
G.3.1.1c)	Thermal cut-outs tested as part of the equipment as indicated in c)		N/A
G.3.1.2	Thermal cut-off connections maintained and secure		N/A
G.3.2	Thermal links		N/A
G.3.2.1a)	Thermal links separately tested with IEC 60691	Not use.	N/A
G.3.2.1b)	Thermal links tested as part of the equipment		N/A
	Aging hours (H)		—
	Single Fault Condition		—
	Test Voltage (V) and Insulation Resistance (Ω) . :		—
G.3.3	PTC Thermistors	Not use.	N/A
G.3.4	Overcurrent protection devices		N/A
G.3.5	Safeguards components not mentioned in G.3.1 to G.3.5		N/A
G.3.5.1	Non-resettable devices suitably rated and marking provided	Not use.	N/A
G.3.5.2	Single faults conditions..... :		N/A
G.4	Connectors		N/A
G.4.1	Spacings	No such parts.	N/A
G.4.2	Mains connector configuration	No such parts.	N/A
G.4.3	Plug is shaped that insertion into mains socket-outlets or appliance coupler is unlikely	No such parts.	N/A
G.5	Wound Components		N/A
G.5.1	Wire insulation in wound components.....	Not use.	N/A
G.5.1.2 a)	Two wires in contact inside wound component, angle between 45° and 90°		N/A
G.5.1.2 b)	Construction subject to routine testing		N/A
G.5.2	Endurance test on wound components		N/A
G.5.2.1	General test requirements		N/A
G.5.2.2	Heat run test		N/A
	Time (s).....		—
	Temperature (°C).....		—
G.5.2.3	Wound Components supplied by mains		N/A
G.5.3	Transformers		N/A
G.5.3.1	Requirements applied (IEC61204-7, IEC61558-1/-2, and/or IEC62368-1).....	Not use.	N/A
	Position		—
	Method of protection		—
G.5.3.2	Insulation		N/A



EN 62368-1			
Clause	Requirement + Test	Result - Remark	Verdict
	Protection from displacement of windings		—
G.5.3.3	Overload test		N/A
G.5.3.3.1	Test conditions		N/A
G.5.3.3.2	Winding Temperatures testing in the unit		N/A
G.5.3.3.3	Winding Temperatures - Alternative test method		N/A
G.5.4	Motors		N/A
G.5.4.1	General requirements	Not use.	N/A
	Position		—
G.5.4.2	Test conditions		N/A
G.5.4.3	Running overload test		N/A
G.5.4.4	Locked-rotor overload test		N/A
	Test duration (days)		—
G.5.4.5	Running overload test for d.c. motors in secondary circuits		N/A
G.5.4.5.2	Tested in the unit		N/A
	Electric strength test (V)		—
G.5.4.5.3	Tested on the Bench - Alternative test method; test time (h)		N/A
	Electric strength test (V)		—
G.5.4.6	Locked-rotor overload test for d.c. motors in secondary circuits		N/A
G.5.4.6.2	Tested in the unit		N/A
	Maximum Temperature		N/A
	Electric strength test (V)		N/A
G.5.4.6.3	Tested on the bench - Alternative test method; test time (h).....		N/A
	Electric strength test (V)		N/A
G.5.4.7	Motors with capacitors		N/A
G.5.4.8	Three-phase motors		N/A
G.5.4.9	Series motors		N/A
	Operating voltage		—
G.6	Wire Insulation		N/A
G.6.1	General	Not use.	N/A
G.6.2	Solvent-based enamel wiring insulation		N/A
G.7	Mains supply cords		N/A
G.7.1	General requirements	Not use.	N/A
	Type.....		—
	Rated current (A)		—



EN 62368-1			
Clause	Requirement + Test	Result - Remark	Verdict
	Cross-sectional area (mm ²), (AWG)..... :		—
G.7.2	Compliance and test method		N/A
G.7.3	Cord anchorages and strain relief for non-detachable power supply cords		N/A
G.7.3.2	Cord strain relief		N/A
G.7.3.2.1	Requirements		N/A
	Strain relief test force (N)..... :		—
G.7.3.2.2	Strain relief mechanism failure		N/A
G.7.3.2.3	Cord sheath or jacket position, distance (mm)..... :		—
G.7.3.2.4	Strain relief comprised of polymeric material		N/A
G.7.4	Cord Entry..... :		N/A
G.7.5	Non-detachable cord bend protection		N/A
G.7.5.1	Requirements		N/A
G.7.5.2	Mass (g)		—
	Diameter (m)..... :		—
	Temperature (°C)..... :		—
G.7.6	Supply wiring space		N/A
G.7.6.2	Stranded wire		N/A
G.7.6.2.1	Test with 8 mm strand		N/A
G.8	Varistors		N/A
G.8.1	General requirements	Not use.	N/A
G.8.2	Safeguard against shock		N/A
G.8.3	Safeguard against fire		N/A
G.8.3.2	Varistor overload test..... :		N/A
G.8.3.3	Temporary overvoltage..... :		N/A
G.9	Integrated Circuit (IC) Current Limiters		N/A
G.9.1 a)	Manufacturer defines limit at max. 5A.	Not use.	N/A
G.9.1 b)	Limiters do not have manual operator or reset		N/A
G.9.1 c)	Supply source does not exceed 250 VA		—
G.9.1 d)	IC limiter output current (max. 5A)		—
G.9.1 e)	Manufacturers' defined drift		—
G.9.2	Test Program 1		N/A
G.9.3	Test Program 2		N/A
G.9.4	Test Program 3		N/A
G.10	Resistors		N/A
G.10.1	General requirements	Resistors are not used as a safeguard.	N/A



EN 62368-1			
Clause	Requirement + Test	Result - Remark	Verdict
G.10.2	Resistor test		N/A
G.10.3	Test for resistors serving as safeguards between the mains and an external circuit consisting of a coaxial cable		N/A
G.10.3.1	General requirements		N/A
G.10.3.2	Voltage surge test		N/A
G.10.3.3	Impulse test		N/A
G.11	Capacitor and RC units		N/A
G.11.1	General requirements	Capacitors are not used as a safeguard.	N/A
G.11.2	Conditioning of capacitors and RC units		N/A
G.11.3	Rules for selecting capacitors		N/A
G.12	Optocouplers		N/A
	Optocouplers comply with IEC 60747-5-5:2007 Spacing or Electric Strength Test (specify option and test results)	Not use.	N/A
	Type test voltage V _{ini}		—
	Routine test voltage, V _{ini,b}		—
G.13	Printed boards		N/A
G.13.1	General requirements	Printed boards are not used as basic insulation, supplementary insulation, reforced insulation and double insulation.	N/A
G.13.2	Uncoated printed boards		N/A
G.13.3	Coated printed boards		N/A
G.13.4	Insulation between conductors on the same inner surface		N/A
	Compliance with cemented joint requirements (Specify construction)		—
G.13.5	Insulation between conductors on different surfaces	No such construction.	N/A
	Distance through insulation		N/A
	Number of insulation layers (pcs)		—
G.13.6	Tests on coated printed boards	No coated printed boards.	N/A
G.13.6.1	Sample preparation and preliminary inspection		N/A
G.13.6.2a)	Thermal conditioning		N/A
G.13.6.2b)	Electric strength test		N/A
G.13.6.2c)	Abrasion resistance test		N/A
G.14	Coating on components terminals		N/A
G.14.1	Requirements	Not use.	N/A



EN 62368-1			
Clause	Requirement + Test	Result - Remark	Verdict
G.15	Liquid filled components		N/A
G.15.1	General requirements	Not use.	N/A
G.15.2	Requirements		N/A
G.15.3	Compliance and test methods		N/A
G.15.3.1	Hydrostatic pressure test		N/A
G.15.3.2	Creep resistance test		N/A
G.15.3.3	Tubing and fittings compatibility test		N/A
G.15.3.4	Vibration test		N/A
G.15.3.5	Thermal cycling test		N/A
G.15.3.6	Force test		N/A
G.15.4	Compliance		N/A
G.16	IC including capacitor discharge function (ICX)		N/A
a)	Humidity treatment in accordance with sc5.4.8 – 120 hours	Not use.	N/A
b)	Impulse test using circuit 2 with $U_c =$ to transient voltage		N/A
C1)	Application of ac voltage at 110% of rated voltage for 2.5 minutes		N/A
C2)	Test voltage		—
D1)	10,000 cycles on and off using capacitor with smallest capacitance resistor with largest resistance specified by manufacturer		N/A
D2)	Capacitance		—
D3)	Resistance		—
H	CRITERIA FOR TELEPHONE RINGING SIGNALS		N/A
H.1	General	No such parts.	N/A
H.2	Method A		N/A
H.3	Method B		N/A
H.3.1	Ringing signal		N/A
H.3.1.1	Frequency (Hz)		—
H.3.1.2	Voltage (V)		—
H.3.1.3	Cadence; time (s) and voltage (V)		—
H.3.1.4	Single fault current (mA):.....		—
H.3.2	Tripping device and monitoring voltage.....		N/A
H.3.2.1	Conditions for use of a tripping device or a monitoring voltage complied with		N/A
H.3.2.2	Tripping device		N/A
H.3.2.3	Monitoring voltage (V)		—



EN 62368-1			
Clause	Requirement + Test	Result - Remark	Verdict
J	INSULATED WINDING WIRES FOR USE WITHOUT INTERLEAVED INSULATION		N/A
	General requirements	Not use.	N/A
K	SAFETY INTERLOCKS		N/A
K.1	General requirements	Not use.	N/A
K.2	Components of safety interlock safeguard mechanism		N/A
K.3	Inadvertent change of operating mode		N/A
K.4	Interlock safeguard override		N/A
K.5	Fail-safe		N/A
	Compliance		N/A
K.6	Mechanically operated safety interlocks		N/A
K.6.1	Endurance requirement		N/A
K.6.2	Compliance and Test method		N/A
K.7	Interlock circuit isolation		N/A
K.7.1	Separation distance for contact gaps & interlock circuit elements (type and circuit location)		N/A
K.7.2	Overload test, Current (A)		N/A
K.7.3	Endurance test		N/A
K.7.4	Electric strength test		N/A
L	DISCONNECT DEVICES		N/A
L.1	General requirements	Class III equipment.	N/A
L.2	Permanently connected equipment		N/A
L.3	Parts that remain energized		N/A
L.4	Single phase equipment		N/A
L.5	Three-phase equipment		N/A
L.6	Switches as disconnect devices		N/A
L.7	Plugs as disconnect devices		N/A
L.8	Multiple power sources		N/A
M	EQUIPMENT CONTAINING BATTERIES AND THEIR PROTECTION CIRCUITS		P
M.1	General requirements	Instructional safeguard has provided in user manual and see below.	P
M.2	Safety of batteries and their cells	See below.	P
M.2.1	Requirements	See append table 4.1.2 for details.	P
M.2.2	Compliance and test method (identify method) ...	See append table 4.1.2 for details.	P
M.3	Protection circuits	See below.	P
M.3.1	Requirements	Complied.	P



EN 62368-1			
Clause	Requirement + Test	Result - Remark	Verdict
M.3.2	Tests	See below.	P
	- Overcharging of a rechargeable battery	The used RTC battery is not a rechargeable battery.	N/A
	- Unintentional charging of a non-rechargeable battery	(See appended table annex M)	P
	- Reverse charging of a rechargeable battery	No charge circuit.	N/A
	- Excessive discharging rate for any battery	No such component.	N/A
M.3.3	Compliance	See appended table annex M.	P
M.4	Additional safeguards for equipment containing secondary lithium battery		N/A
M.4.1	General		N/A
M.4.2	Charging safeguards		N/A
M.4.2.1	Charging operating limits		N/A
M.4.2.2a)	Charging voltage, current and temperature		—
M.4.2.2 b)	Single faults in charging circuitry.....		—
M.4.3	Fire Enclosure		N/A
M.4.4	Endurance of equipment containing a secondary lithium battery		N/A
M.4.4.2	Preparation		N/A
M.4.4.3	Drop and charge/discharge function tests		N/A
	Drop		N/A
	Charge		N/A
	Discharge		N/A
M.4.4.4	Charge-discharge cycle test		N/A
M.4.4.5	Result of charge-discharge cycle test		N/A
M.5	Risk of burn due to short circuit during carrying		N/A
M.5.1	Requirement		N/A
M.5.2	Compliance and Test Method (Test of P.2.3)		N/A
M.6	Prevention of short circuits and protection from other effects of electric current		N/A
M.6.1	Short circuits		N/A
M.6.1.1	General requirements		N/A
M.6.1.2	Test method to simulate an internal fault		N/A
M.6.1.3	Compliance (Specify M.6.1.2 or alternative method)		N/A
M.6.2	Leakage current (mA)		N/A
M.7	Risk of explosion from lead acid and NiCd batteries		N/A



EN 62368-1			
Clause	Requirement + Test	Result - Remark	Verdict
M.7.1	Ventilation preventing explosive gas concentration		N/A
M.7.2	Compliance and test method		N/A
M.8	Protection against internal ignition from external spark sources of lead acid batteries		N/A
M.8.1	General requirements		N/A
M.8.2	Test method		N/A
M.8.2.1	General requirements		N/A
M.8.2.2	Estimation of hypothetical volume V_z (m ³ /s).....:		—
M.8.2.3	Correction factors		—
M.8.2.4	Calculation of distance d (mm)		—
M.9	Preventing electrolyte spillage		N/A
M.9.1	Protection from electrolyte spillage		N/A
M.9.2	Tray for preventing electrolyte spillage		N/A
M.10	Instructions to prevent reasonably foreseeable misuse (Determination of compliance: inspection, data review; or abnormal testing)		N/A
N	ELECTROCHEMICAL POTENTIALS		N/A
	Metal(s) used.....:		—
O	MEASUREMENT OF CREEPAGE DISTANCES AND CLEARANCES		N/A
	Figures O.1 to O.20 of this Annex applied		—
P	SAFEGUARDS AGAINST ENTRY OF FOREIGN OBJECTS AND SPILLAGE OF INTERNAL LIQUIDS		N/A
P.1	General requirements	No openings.	N/A
P.2.2	Safeguards against entry of foreign object		N/A
	Location and Dimensions (mm)		—
P.2.3	Safeguard against the consequences of entry of foreign object		N/A
P.2.3.1	Safeguards against the entry of a foreign object		N/A
	Openings in transportable equipment	Not transportable equipment.	N/A
	Transportable equipment with metalized plastic parts.....:		N/A
P.2.3.2	Openings in transportable equipment in relation to metallized parts of a barrier or enclosure (identification of supplementary safeguard)	Not transportable equipment.	N/A
P.3	Safeguards against spillage of internal liquids	No such parts.	N/A
P.3.1	General requirements		N/A
P.3.2	Determination of spillage consequences		N/A
P.3.3	Spillage safeguards		N/A



EN 62368-1			
Clause	Requirement + Test	Result - Remark	Verdict
P.3.4	Safeguards effectiveness		N/A
P.4	Metallized coatings and adhesive securing parts	No such parts.	N/A
P.4.2 a)	Conditioning testing		N/A
	Tc (°C)		—
	Tr (°C).....		—
	Ta (°C).....		—
P.4.2 b)	Abrasion testing		N/A
P.4.2 c)	Mechanical strength testing		N/A
Q	CIRCUITS INTENDED FOR INTERCONNECTION WITH BUILDING WIRING		P
Q.1	Limited power sources	See below.	P
Q.1.1 a)	Inherently limited output	(See appended table Annex Q.1.)	P
Q.1.1 b)	Impedance limited output	Not selected.	N/A
	- Regulating network limited output under normal operating and simulated single fault condition	Not selected.	N/A
Q.1.1 c)	Overcurrent protective device limited output	Not selected.	N/A
Q.1.1 d)	IC current limiter complying with G.9	Not selected.	N/A
Q.1.2	Compliance and test method	(See appended table Annex Q.1)	P
Q.2	Test for external circuits – paired conductor cable	Not selected.	N/A
	Maximum output current (A)		—
	Current limiting method		—
R	LIMITED SHORT CIRCUIT TEST		N/A
R.1	General requirements	Class III equipment.	N/A
R.2	Determination of the overcurrent protective device and circuit		N/A
R.3	Test method Supply voltage (V) and short-circuit current (A).		N/A
S	TESTS FOR RESISTANCE TO HEAT AND FIRE		N/A
S.1	Flammability test for fire enclosures and fire barrier materials of equipment where the steady state power does not exceed 4 000 W		N/A
	Samples, material.....		—
	Wall thickness (mm)		—
	Conditioning (°C)		—
	Test flame according to IEC 60695-11-5 with conditions as set out		N/A
	- Material not consumed completely		N/A
	- Material extinguishes within 30s		N/A
	- No burning of layer or wrapping tissue		N/A



EN 62368-1			
Clause	Requirement + Test	Result - Remark	Verdict
S.2	Flammability test for fire enclosure and fire barrier integrity		N/A
	Samples, material.....:		—
	Wall thickness (mm)		—
	Conditioning (°C)		—
	Test flame according to IEC 60695-11-5 with conditions as set out		N/A
	Test specimen does not show any additional hole		N/A
S.3	Flammability test for the bottom of a fire enclosure		N/A
	Samples, material.....:		—
	Wall thickness (mm)		—
	Cheesecloth did not ignite		N/A
S.4	Flammability classification of materials		N/A
S.5	Flammability test for fire enclosures and fire barrier materials of equipment where the steady state power does not exceed 4 000 W		N/A
	Samples, material.....:		—
	Wall thickness (mm)		—
	Conditioning (test condition), (°C)		—
	Test flame according to IEC 60695-11-20 with conditions as set out		N/A
	- After every test specimen was not consumed completely		N/A
	- After fifth flame application, flame extinguished within 1 min		N/A
T	MECHANICAL STRENGTH TESTS		P
T.1	General requirements	See below.	P
T.2	Steady force test, 10 N	(See appended table T.2, T.3, T.4, T.5)	P
T.3	Steady force test, 30 N		N/A
T.4	Steady force test, 100 N		N/A
T.5	Steady force test, 250 N		N/A
T.6	Enclosure impact test		N/A
	Fall test		N/A
	Swing test		N/A
T.7	Drop test		N/A
T.8	Stress relief test.....:		N/A
T.9	Impact Test (glass)		N/A
T.9.1	General requirements		N/A



EN 62368-1			
Clause	Requirement + Test	Result - Remark	Verdict
T.9.2	Impact test and compliance		N/A
	Impact energy (J)..... :		—
	Height (m) :		—
T.10	Glass fragmentation test :		N/A
T.11	Test for telescoping or rod antennas		N/A
	Torque value (Nm) :		—
U	MECHANICAL STRENGTH OF CATHODE RAY TUBES (CRT) AND PROTECTION AGAINST THE EFFECTS OF IMPLOSION		N/A
U.1	General requirements	No CRT inside the EUT.	N/A
U.2	Compliance and test method for non-intrinsically protected CRTs		N/A
U.3	Protective Screen :		N/A
V	DETERMINATION OF ACCESSIBLE PARTS (FINGERS, PROBES AND WEDGES)		P
V.1	Accessible parts of equipment	Complied.	P
V.2	Accessible part criterion	Complied.	P



EN 62368-1																																							
Clause	Requirement + Test	Result - Remark	Verdict																																				
ATTACHMENT TO TEST REPORT IEC 62368-1 EUROPEAN GROUP DIFFERENCES AND NATIONAL DIFFERENCES (Audio/video, information and communication technology equipment - Part 1: Safety requirements)																																							
Differences according to: EN 62368-1:2014+A11:2017																																							
Attachment Form No.....: EU_GD_IEC62368_1D_II																																							
Attachment Originator: Nemko AS																																							
Master Attachment: Date 2021-02-04																																							
Copyright © 2021 IEC System for Conformity Testing and Certification of Electrical Equipment (IECEE), Geneva, Switzerland. All rights reserved.																																							
CENELEC COMMON MODIFICATIONS (EN)																																							
	Clauses, subclauses, notes, tables, figures and annexes which are additional to those in IEC 62368-1:2014 are prefixed "Z".		--																																				
CONTENTS	Add the following annexes: Annex ZA (normative) Normative references to international publications with their corresponding European publications Annex ZB (normative) Special national conditions Annex ZC (informative) A-deviations Annex ZD (informative) IEC and CENELEC code designations for flexible cords		P																																				
	Delete all the "country" notes in the reference document (IEC 62368-1:2014) according to the following list: <table border="1" style="width: 100%; border-collapse: collapse;"> <tbody> <tr> <td style="width: 15%;">0.2.1</td> <td style="width: 15%;">Note</td> <td style="width: 15%;">1</td> <td style="width: 15%;">Note 3</td> <td style="width: 15%;">4.1.15</td> <td style="width: 15%;">Note</td> </tr> <tr> <td>4.7.3</td> <td>Note 1 and 2</td> <td>5.2.2.2</td> <td>Note</td> <td>5.4.2.3.2.2 Table 13</td> <td>Note c</td> </tr> <tr> <td>5.4.2.3.2.4</td> <td>Note 1 and 3</td> <td>5.4.2.5</td> <td>Note 2</td> <td>5.4.5.1</td> <td>Note</td> </tr> <tr> <td>5.5.2.1</td> <td>Note</td> <td>5.5.6</td> <td>Note</td> <td>5.6.4.2.1</td> <td>Note 2 and 3</td> </tr> <tr> <td>5.7.5</td> <td>Note</td> <td>5.7.6.1</td> <td>Note 1 and 2</td> <td>10.2.1 Table 39</td> <td>Note 2, 3 and 4</td> </tr> <tr> <td>10.5.3</td> <td>Note 2</td> <td>10.6.2.1</td> <td>Note 3</td> <td>F.3.3.6</td> <td>Note 3</td> </tr> </tbody> </table>		0.2.1	Note	1	Note 3	4.1.15	Note	4.7.3	Note 1 and 2	5.2.2.2	Note	5.4.2.3.2.2 Table 13	Note c	5.4.2.3.2.4	Note 1 and 3	5.4.2.5	Note 2	5.4.5.1	Note	5.5.2.1	Note	5.5.6	Note	5.6.4.2.1	Note 2 and 3	5.7.5	Note	5.7.6.1	Note 1 and 2	10.2.1 Table 39	Note 2, 3 and 4	10.5.3	Note 2	10.6.2.1	Note 3	F.3.3.6	Note 3	P
0.2.1	Note	1	Note 3	4.1.15	Note																																		
4.7.3	Note 1 and 2	5.2.2.2	Note	5.4.2.3.2.2 Table 13	Note c																																		
5.4.2.3.2.4	Note 1 and 3	5.4.2.5	Note 2	5.4.5.1	Note																																		
5.5.2.1	Note	5.5.6	Note	5.6.4.2.1	Note 2 and 3																																		
5.7.5	Note	5.7.6.1	Note 1 and 2	10.2.1 Table 39	Note 2, 3 and 4																																		
10.5.3	Note 2	10.6.2.1	Note 3	F.3.3.6	Note 3																																		
	For special national conditions, see Annex ZB.		P																																				
1	Add the following note: NOTE Z1 The use of certain substances in electrical and electronic equipment is restricted within the EU: see Directive 2011/65/EU.		N/A																																				



EN 62368-1			
Clause	Requirement + Test	Result - Remark	Verdict
4.Z1	<p>Add the following new subclause after 4.9:</p> <p>To protect against excessive current, short-circuits and earth faults in circuits connected to an a.c. mains, protective devices shall be included either as integral parts of the equipment or as parts of the building installation, subject to the following, a), b) and c):</p> <p>a) except as detailed in b) and c), protective devices necessary to comply with the requirements of B.3.1 and B.4 shall be included as parts of the equipment;</p> <p>b) for components in series with the mains input to the equipment such as the supply cord, appliance coupler, r.f.i. filter and switch, short-circuit and earth fault protection may be provided by protective devices in the building installation;</p> <p>c) it is permitted for pluggable equipment type B or permanently connected equipment, to rely on dedicated overcurrent and short-circuit protection in the building installation, provided that the means of protection, e.g. fuses or circuit breakers, is fully specified in the installation instructions.</p> <p>If reliance is placed on protection in the building installation, the installation instructions shall so state, except that for pluggable equipment type A the building installation shall be regarded as providing protection in accordance with the rating of the wall socket outlet.</p>	Class III appliance.	N/A
5.4.2.3.2.4	<p>Add the following to the end of this subclause:</p> <p>The requirement for interconnection with external circuit is in addition given in EN 50491-3:2009.</p>		N/A
10.2.1	<p>Add the following to c) and d) in table 39:</p> <p>For additional requirements, see 10.5.1.</p>	See below.	P



EN 62368-1			
Clause	Requirement + Test	Result - Remark	Verdict
10.5.1	<p>Add the following after the first paragraph: <i>For RS 1 compliance is checked by measurement under the following conditions:</i></p> <p><i>In addition to the normal operating conditions, all controls adjustable from the outside by hand, by any object such as a tool or a coin, and those internal adjustments or presets which are not locked in a reliable manner, are adjusted so as to give maximum radiation whilst maintaining an intelligible picture for 1 h, at the end of which the measurement is made.</i></p> <p>NOTE Z1 Soldered joints and paint lockings are examples of adequate locking.</p> <p><i>The dose-rate is determined by means of a radiation monitor with an effective area of 10 cm², at any point 10 cm from the outer surface of the apparatus.</i></p> <p><i>Moreover, the measurement shall be made under fault conditions causing an increase of the high-voltage, provided an intelligible picture is maintained for 1 h, at the end of which the measurement is made.</i></p> <p><i>For RS1, the dose-rate shall not exceed 1 μSv/h taking account of the background level.</i></p> <p>NOTE Z2 These values appear in Directive 96/29/Euratom of 13 May 1996.</p>	RS1 for the LED indicators.	P
10.6.1	<p>Add the following paragraph to the end of the subclause: EN 71-1:2011, 4.20 and the related tests methods and measurement distances apply.</p>		N/A
10.Z1	<p>Add the following new subclause after 10.6.5. 10.Z1 Non-ionizing radiation from radio frequencies in the range 0 to 300 GHz</p> <p>The amount of non-ionizing radiation is regulated by European Council Recommendation 1999/519/EC of 12 July 1999 on the limitation of exposure of the general public to electromagnetic fields (0 Hz to 300 GHz).</p> <p>For intentional radiators, ICNIRP guidelines should be taken into account for Limiting Exposure to Time-Varying Electric, Magnetic, and Electromagnetic Fields (up to 300 GHz). For hand-held and body-mounted devices, attention is drawn to EN 50360 and EN 50566</p>	Not such equipment	N/A
G.7.1	<p>Add the following note: NOTE Z1 The harmonized code designations corresponding to the IEC cord types are given in Annex ZD.</p>	No mains supply cord used	N/A



EN 62368-1			
Clause	Requirement + Test	Result - Remark	Verdict
Bibliography	<p>Add the following standards:</p> <p>Add the following notes for the standards indicated:</p> <p>IEC 60130-9 NOTE Harmonized as EN 60130-9.</p> <p>IEC 60269-2 NOTE Harmonized as HD 60269-2.</p> <p>IEC 60309-1 NOTE Harmonized as EN 60309-1.</p> <p>IEC 60364 NOTE some parts harmonized in HD 384/HD 60364 series.</p> <p>IEC 60601-2-4 NOTE Harmonized as EN 60601-2-4.</p> <p>IEC 60664-5 NOTE Harmonized as EN 60664-5.</p> <p>IEC 61032:1997 NOTE Harmonized as EN 61032:1998 (not modified).</p> <p>IEC 61508-1 NOTE Harmonized as EN 61508-1.</p> <p>IEC 61558-2-1 NOTE Harmonized as EN 61558-2-1.</p> <p>IEC 61558-2-4 NOTE Harmonized as EN 61558-2-4.</p> <p>IEC 61558-2-6 NOTE Harmonized as EN 61558-2-6.</p> <p>IEC 61643-1 NOTE Harmonized as EN 61643-1.</p> <p>IEC 61643-21 NOTE Harmonized as EN 61643-21.</p> <p>IEC 61643-311 NOTE Harmonized as EN 61643-311.</p> <p>IEC 61643-321 NOTE Harmonized as EN 61643-321.</p> <p>IEC 61643-331 NOTE Harmonized as EN 61643-331.</p>		N/A
ZB	ANNEX ZB, SPECIAL NATIONAL CONDITIONS (EN)		
4.1.15	<p>Denmark, Finland, Norway and Sweden</p> <p>To the end of the subclause the following is added:</p> <p>Class I pluggable equipment type A intended for connection to other equipment or a network shall, if safety relies on connection to reliable earthing or if surge suppressors are connected between the network terminals and accessible parts, have a marking stating that the equipment shall be connected to an earthed mains socket-outlet.</p> <p>The marking text in the applicable countries shall be as follows:</p> <p>In Denmark: "Apparatets stikprop skal tilsluttes en stikkontakt med jord som giver forbindelse til stikproppens jord."</p> <p>In Finland: "Laite on liitettävä suojakoskettimilla varustettuun pistorasiaan"</p> <p>In Norway: "Apparatet må tilkoples jordet stikkontakt"</p> <p>In Sweden: "Apparaten skall anslutas till jordat uttag"</p>	Class III appliance.	N/A
4.7.3	<p>United Kingdom</p> <p>To the end of the subclause the following is added:</p> <p>The torque test is performed using a socket-outlet complying with BS 1363, and the plug part shall be assessed to the relevant clauses of BS 1363. Also see Annex G.4.2 of this annex</p>	Class III appliance.	N/A



EN 62368-1			
Clause	Requirement + Test	Result - Remark	Verdict
5.2.2.2	<p>Denmark</p> <p>After the 2nd paragraph add the following: A warning (marking safeguard) for high touch current is required if the touch current exceeds the limits of 3,5 mA a.c. or 10 mA d.c.</p>	Class III appliance.	N/A
5.4.11.1 and Annex G	<p>Finland and Sweden</p> <p>To the end of the subclause the following is added: For separation of the telecommunication network from earth the following is applicable: If this insulation is solid, including insulation forming part of a component, it shall at least consist of either</p> <ul style="list-style-type: none"> • two layers of thin sheet material, each of which shall pass the electric strength test below, or • one layer having a distance through insulation of at least 0,4 mm, which shall pass the electric strength test below. <p>If this insulation forms part of a semiconductor component (e.g. an optocoupler), there is no distance through insulation requirement for the insulation consisting of an insulating compound completely filling the casing, so that clearances and creepage distances do not exist, if the component passes the electric strength test in accordance with the compliance clause below and in addition</p> <ul style="list-style-type: none"> • passes the tests and inspection criteria of 5.4.8 with an electric strength test of 1,5 kV multiplied by 1,6 (the electric strength test of 5.4.9 shall be performed using 1,5 kV), and • is subject to routine testing for electric strength during manufacturing, using a test voltage of 1,5kV. <p>It is permitted to bridge this insulation with a capacitor complying with EN 60384-14:2005, subclass Y2. A capacitor classified Y3 according to EN 60384-14:2005, may bridge this insulation under the following conditions:</p> <ul style="list-style-type: none"> • the insulation requirements are satisfied by having a capacitor classified Y3 as defined by EN 60384-14, which in addition to the Y3 testing, is tested with an impulse test of 2,5 kV defined in 5.4.11; • the additional testing shall be performed on all the test specimens as described in EN 60384-14; the impulse test of 2,5 kV is to be performed before the endurance test in EN 60384-14, in the sequence of tests as described in EN 60384-14. 	Class III appliance.	N/A



EN 62368-1			
Clause	Requirement + Test	Result - Remark	Verdict
5.5.2.1	Norway After the 3rd paragraph the following is added: Due to the IT power system used, capacitors are required to be rated for the applicable line-to-line voltage (230 V).	Class III appliance.	N/A
5.5.6	Finland, Norway and Sweden To the end of the subclause the following is added: Resistors used as basic safeguard or bridging basic insulation in class I pluggable equipment type A shall comply with G.10.1 and the test of G.10.2.	Class III appliance.	N/A
5.6.1	Denmark Add to the end of the subclause Due to many existing installations where the socket-outlets can be protected with fuses with higher rating than the rating of the socket-outlets the protection for pluggable equipment type A shall be an integral part of the equipment. <i>Justification:</i> In Denmark an existing 13 A socket outlet can be protected by a 20 A fuse.	Class III appliance.	N/A
5.6.4.2.1	Ireland and United Kingdom After the indent for pluggable equipment type A , the following is added: – the protective current rating is taken to be 13 A, this being the largest rating of fuse used in the mains plug.	Class III appliance.	N/A
5.6.5.1	To the second paragraph the following is added: The range of conductor sizes of flexible cords to be accepted by terminals for equipment with a rated current over 10 A and up to and including 13 A is: 1,25 mm ² to 1,5 mm ² in cross-sectional area.	Class III appliance.	N/A
5.7.5	Denmark To the end of the subclause the following is added: The installation instruction shall be affixed to the equipment if the protective conductor current exceeds the limits of 3,5 mA a.c. or 10 mA d.c.	Class III appliance.	N/A



EN 62368-1			
Clause	Requirement + Test	Result - Remark	Verdict
5.7.6.1	<p>Norway and Sweden</p> <p>To the end of the subclause the following is added:</p> <p>The screen of the television distribution system is normally not earthed at the entrance of the building and there is normally no equipotential bonding system within the building. Therefore the protective earthing of the building installation needs to be isolated from the screen of a cable distribution system.</p> <p>It is however accepted to provide the insulation external to the equipment by an adapter or an interconnection cable with galvanic isolator, which may be provided by a retailer, for example.</p> <p>The user manual shall then have the following or similar information in Norwegian and Swedish language respectively, depending on in what country the equipment is intended to be used in:</p> <p>“Apparatus connected to the protective earthing of the building installation through the mains connection or through other apparatus with a connection to protective earthing – and to a television distribution system using coaxial cable, may in some circumstances create a fire hazard. Connection to a television distribution system therefore has to be provided through a device providing electrical isolation below a certain frequency range (galvanic isolator, see EN 60728-11)”</p> <p>NOTE In Norway, due to regulation for CATV-installations, and in Sweden, a galvanic isolator shall provide electrical insulation below 5 MHz. The insulation shall withstand a dielectric strength of 1,5 kV r.m.s., 50 Hz or 60 Hz, for 1 min.</p> <p>Translation to Norwegian (the Swedish text will also be accepted in Norway):</p> <p>“Apparater som er koplet til beskyttelsesjord via nettplugg og/eller via annet jordtilkoplet utstyr – og er tilkoplet et koaksialbasert kabel-TV nett, kan forårsake brannfare. For å unngå dette skal det ved tilkopling av apparater til kabel-TV nett installeres en galvanisk isolator mellom apparatet og kabel-TV nettet.”</p> <p>Translation to Swedish:</p> <p>”Apparater som är kopplad till skyddsjord via jordat vägguttag och/eller via annan utrustning och samtidigt är kopplad till kabel-TV nät kan i vissa fall medföra risk för brand. För att undvika detta skall vid anslutning av apparaten till kabel-TV nät galvanisk isolator finnas mellan apparaten och kabel-TV nätet.”</p>	Not connected to television distribution system.	N/A



EN 62368-1			
Clause	Requirement + Test	Result - Remark	Verdict
5.7.6.2	<p>Denmark</p> <p>To the end of the subclause the following is added: The warning (marking safeguard) for high touch current is required if the touch current or the protective current exceed the limits of 3,5 mA .</p>	Class III appliance.	N/A
B.3.1 and B.4	<p>Ireland and United Kingdom</p> <p>The following is applicable: To protect against excessive currents and short-circuits in the primary circuit of direct plug-in equipment, tests according to Annexes B.3.1 and B.4 shall be conducted using an external miniature circuit breaker complying with EN 60898-1, Type B, rated 32A. If the equipment does not pass these tests, suitable protective devices shall be included as an integral part of the direct plug-in equipment, until the requirements of Annexes B.3.1 and B.4 are met</p>	Class III appliance.	N/A
G.4.2	<p>Denmark</p> <p>To the end of the subclause the following is added: Supply cords of single phase appliances having a rated current not exceeding 13 A shall be provided with a plug according to DS 60884-2-D1:2011. CLASS I EQUIPMENT provided with socket-outlets with earth contacts or which are intended to be used in locations where protection against indirect contact is required according to the wiring rules shall be provided with a plug in accordance with standard sheet DK 2-1a or DK 2-5a. If a single-phase equipment having a RATED CURRENT exceeding 13 A or if a poly-phase equipment is provided with a supply cord with a plug, this plug shall be in accordance with the standard sheets DK 6-1a in DS 60884-2-D1 or EN 60309-2. Mains socket outlets intended for providing power to Class II apparatus with a rated current of 2,5 A shall be in accordance DS 60884-2-D1:2011 standard sheet DKA 1-4a. Other current rating socket outlets shall be in compliance with Standard Sheet DKA 1-3a or DKA 1-1c. Mains socket-outlets with earth shall be in compliance with DS 60884-2-D1:2011 Standard Sheet DK 1-3a, DK 1-1c, DK1-1d, DK 1-5a or DK 1-7a <i>Justification:</i> Heavy Current Regulations, Section 6c</p>	Class III appliance.	N/A



EN 62368-1			
Clause	Requirement + Test	Result - Remark	Verdict
G.4.2	<p>United Kingdom</p> <p>To the end of the subclause the following is added: The plug part of direct plug-in equipment shall be assessed to BS 1363: Part 1, 12.1, 12.2, 12.3, 12.9, 12.11, 12.12, 12.13, 12.16, and 12.17, except that the test of 12.17 is performed at not less than 125 °C. Where the metal earth pin is replaced by an Insulated Shutter Opening Device (ISOD), the requirements of clauses 22.2 and 23 also apply.</p>	Class III appliance.	N/A
G.7.1	<p>United Kingdom</p> <p>To the first paragraph the following is added: Equipment which is fitted with a flexible cable or cord and is designed to be connected to a mains socket conforming to BS 1363 by means of that flexible cable or cord shall be fitted with a 'standard plug' in accordance with the Plugs and Sockets etc (Safety) Regulations 1994, Statutory Instrument 1994 No. 1768, unless exempted by those regulations.</p> <p>NOTE "Standard plug" is defined in SI 1768:1994 and essentially means an approved plug conforming to BS 1363 or an approved conversion plug.</p>	Class III appliance.	N/A
G.7.1	<p>Ireland</p> <p>To the first paragraph the following is added: Apparatus which is fitted with a flexible cable or cord shall be provided with a plug in accordance with Statutory Instrument 525: 1997, "13 A Plugs and Conversion Adapters for Domestic Use Regulations: 1997. S.I. 525 provides for the recognition of a standard of another Member State which is equivalent to the relevant Irish Standard</p>	Class III appliance.	N/A
G.7.2	<p>Ireland and United Kingdom</p> <p>To the first paragraph the following is added: A power supply cord with a conductor of 1,25 mm² is allowed for equipment which is rated over 10 A and up to and including 13 A.</p>	Class III appliance.	N/A



EN 62368-1			
Clause	Requirement + Test	Result - Remark	Verdict
ZC	ANNEX ZC, NATIONAL DEVIATIONS (EN)		—
10.5.2	<p>Germany</p> <p>The following requirement applies: For the operation of any cathode ray tube intended for the display of visual images operating at an acceleration voltage exceeding 40 kV, authorization is required, or application of type approval (Bauartzulassung) and marking.</p> <p><i>Justification:</i> German ministerial decree against ionizing radiation (Röntgenverordnung), in force since 2002-07-01, implementing the European Directive 96/29/EURATOM.</p> <p>NOTE Contact address: Physikalisch-Technische Bundesanstalt, Bundesallee 100, D-38116 Braunschweig, Tel.: Int +49-531-592-6320, Internet: http://www.ptb.de</p>	No such devices	N/A



EN 62368-1			
Clause	Requirement + Test	Result - Remark	Verdict

4.1.2	TABLE: List of critical components					P
Object / part No.	Manufacturer/ trademark	Type / model	Technical data	Standard	Mark(s) of conformity ¹	
Metal enclosure	Interchangeable	Interchangeable	Metal, Measured thickness 1.0 mm.	IEC 62368-1	Tested in this report	
-Description:	Interchangeable based on standardized dimensions and specified rating.					
RTC battery (BAT1)	Tohoku Murata Manufacturing Co., Ltd.	CR2032W*	3Vdc, max. abnormal charging current 10mA	UL 1642	UL (MH12566)	
- Alternate use	Interchangeable	CR2032W*	3Vdc, max. abnormal charging current 10mA	UL 1642, IEC 60086-4	UL, Notify Body of CB Scheme or CENELEC or equivalent	
-Description:	Interchangeable based on standardized dimensions and specified rating.					
PWB	EISO Enterprise Co Ltd	6	V-0, 130°C min.	UL 796	UL (E162061)	
- Alternate use	Interchangeable	Interchangeable	V-1 or better, 105°C min.	UL 796	UL	
-Description:	Interchangeable based on standardized dimensions and specified rating.					
Supplementary information:						
1) Provided evidence ensures the agreed level of compliance. See OD-CB2039.						



EN 62368-1			
Clause	Requirement + Test	Result - Remark	Verdict
4.8.4, 4.8.5	TABLE: Lithium coin/button cell batteries mechanical tests		N/A
(The following mechanical tests are conducted in the sequence noted.)			
4.8.4.2	TABLE: Stress Relief test		—
	Part	Material	Oven Temperature (°C)
4.8.4.3	TABLE: Battery replacement test		—
	Battery part no.....:		—
	Battery Installation/withdrawal	Battery Installation/Removal Cycle	Comments
		1	
		2	
		3	
		4	
		5	
		6	
		7	
		8	
		9	
		10	
4.8.4.4	TABLE: Drop test		—
	Impact Area	Drop Distance	Drop No.
			1
			2
			3
4.8.4.5	TABLE: Impact		—
	Impacts per surface	Surface tested	Impact energy (Nm)
4.8.4.6	TABLE: Crush test		—
	Test position	Surface tested	Crushing Force (N)
			Duration force applied (s)
Supplementary information:			
4.8.5	TABLE: Lithium coin/button cell batteries mechanical test result		N/A
	Test position	Surface tested	Force (N)
			Duration force applied (s)
Supplementary information:			



EN 62368-1			
Clause	Requirement + Test	Result - Remark	Verdict

5.2	Table: Classification of electrical energy sources		N/A
------------	---	--	-----

5.2.2.2 – Steady State Voltage and Current conditions

No.	Supply Voltage	Location (e.g. circuit designation)	Test conditions	Parameters			ES Class
				U (Vrms or Vpk)	I (Apk or Arms)	Hz	
			Normal				
			Abnormal				
			Single fault – SC/OC				

5.2.2.3 - Capacitance Limits

No.	Supply Voltage	Location (e.g. circuit designation)	Test conditions	Parameters		ES Class
				Capacitance, nF	Upk (V)	
			Normal			
			Abnormal			
			Single fault – SC/OC			

5.2.2.4 - Single Pulses

No.	Supply Voltage	Location (e.g. circuit designation)	Test conditions	Parameters			ES Class
				Duration (ms)	Upk (V)	Ipk (mA)	
			Normal				
			Abnormal				
			Single fault – SC/OC				

5.2.2.5 - Repetitive Pulses

No.	Supply Voltage	Location (e.g. circuit designation)	Test conditions	Parameters			ES Class
				Off time (ms)	Upk (V)	Ipk (mA)	
			Normal				
			Abnormal				
			Single fault – SC/OC				

Test Conditions:

Normal –

Abnormal -

Supplementary information: SC=Short Circuit, OC=Short Circuit



EN 62368-1					
Clause	Requirement + Test	Result - Remark			Verdict
5.4.1.4, 6.3.2, 9.0, B.2.6	TABLE: Temperature measurements				P
	Supply voltage (V)	9Vdc Supplied by External terminal block (Desktop mode)		50Vdc Supplied by External terminal block (Desktop mode)	
	Ambient Tmin (°C)	21.6		21.8	
	Ambient Tmax (°C)	21.6		21.8	
	Tma (°C)	25.0	55.0	25.0	55.0
Maximum measured temperature T of part/at:		T (°C)			Allowed T _{max} (°C)
PWB near U10 (MB board)		--	67.0	--	76.4
PWB near U15 (MB board)		--	67.0	--	76.7
PWB near J4 (MB board)		--	67.9	--	77.3
CT1 body (MB board)		--	66.2	--	78.6
RTC body (MB board)		--	65.6	--	77.3
PWB near U3 (Expansion board)		--	63.2	--	71.8
Metal enclosure outside near top		29.5	--	33.6	--
	Supply voltage (V)	9Vdc Supplied by External terminal block (Wall-mounted, Horizontal mode)		50Vdc Supplied by External terminal block (Wall-mounted, Horizontal mode)	
	Ambient Tmin (°C)	22.0		22.3	
	Ambient Tmax (°C)	22.0		22.3	
	Tma (°C)	25.0	55.0	25.0	55.0
Maximum measured temperature T of part/at:		T (°C)			Allowed T _{max} (°C)
PWB near U10 (MB board)		--	65.7	--	75.3
PWB near U15 (MB board)		--	65.5	--	75.6
PWB near J4 (MB board)		--	66.5	--	76.6
CT1 body (MB board)		--	64.3	--	75.4
RTC body (MB board)		--	63.9	--	75.6
PWB near U3 (Expansion board)		--	61.9	--	70.2
Metal enclosure outside near top		28.6	--	32.8	--



EN 62368-1

Clause	Requirement + Test	Result - Remark	Verdict
--------	--------------------	-----------------	---------

	Supply voltage (V)	9Vdc Supplied by External terminal block (Wall-mounted, Vertical mode)	50Vdc Supplied by External terminal block (Wall-mounted, Vertical mode)			—	
	Ambient Tmin (°C)	22.4	22.4			—	
	Ambient Tmax (°C)	22.4	22.4			—	
	Tma (°C)	25.0	55.0	25.0	55.0	—	
Maximum measured temperature T of part/at:		T (°C)				Allowed T _{max} (°C)	
PWB near U10 (MB board)		--	66.0	--	74.6	105	
PWB near U15 (MB board)		--	65.8	--	74.8	105	
PWB near J4 (MB board)		--	66.8	--	75.3	105	
CT1 body (MB board)		--	65.0	--	76.0	105	
RTC body (MB board)		--	64.5	--	75.6	--	
PWB near U3 (Expansion board)		--	62.2	--	69.2	105	
Metal enclosure outside near top		28.6	--	32.8	--	70	
Temperature T of winding:	t1 (°C)	R1 (Ω)	t2 (°C)	R2 (Ω)	T (°C)	Allowed T _{max} (°C)	Insulation class
--	--	--	--	--	--	--	--

Supplementary information:

Note 1: Tma should be considered as directed by applicable requirement.

Note 2: Tma is not included in assessment of Touch Temperatures (Clause 9).

Note 3: The unit was operated continuously under the Ventilation Openings Blocked.

5.4.1.10.2	TABLE: Vicat softening temperature of thermoplastics	N/A
-------------------	---	-----

Penetration (mm)		—
------------------------	--	---

Object/ Part No./Material	Manufacturer/trademark	T softening (°C)

Supplementary information:

5.4.1.10.3	TABLE: Ball pressure test of thermoplastics	N/A
-------------------	--	-----

Allowed impression diameter (mm)	≤ 2 mm	—
--	--------	---

Object/Part No./Material	Manufacturer/trademark	Test temperature (°C)	Impression diameter (mm)

Supplementary information:

5.4.2.2, 5.4.2.4 and 5.4.3	TABLE: Minimum Clearances/Creepage distance	N/A
---	--	-----



EN 62368-1							
Clause	Requirement + Test			Result - Remark			Verdict
Clearance (cl) and creepage distance (cr) at/of/between:	Up (V)	U r.m.s. (V)	Frequency (kHz) ¹⁾	Required cl (mm)	cl (mm) ²⁾	Required ³⁾ cr (mm)	cr (mm)
Supplementary information: Note 1: Only for frequency above 30 kHz Note 2: See table 5.4.2.4 if this is based on electric strength test Note 3: Provide Material Group							

5.4.2.3	TABLE: Minimum Clearances distances using required withstand voltage			N/A
	Overvoltage Category (OV):			
	Pollution Degree:			
Clearance distanced between:	Required withstand voltage	Required cl (mm)	Measured cl (mm)	
Supplementary information:				

5.4.2.4	TABLE: Clearances based on electric strength test			N/A
Test voltage applied between:	Required cl (mm)	Test voltage (kV) peak/ r.m.s. / d.c.	Breakdown Yes / No	
Supplementary information:				

5.4.4.2, 5.4.4.5 c) 5.4.4.9	TABLE: Distance through insulation measurements					N/A
Distance through insulation di at/of:	Peak voltage (V)	Frequency (kHz)	Material	Required DTI (mm)	DTI (mm)	
Supplementary information:						

5.4.9	TABLE: Electric strength tests			N/A
Test voltage applied between:	Voltage shape (AC, DC)	Test voltage (V)	Breakdown Yes / No	
Functional:				
Basic/supplementary:				
Reinforced:				
Routine Tests:				



EN 62368-1

Clause	Requirement + Test	Result - Remark	Verdict
--------	--------------------	-----------------	---------

Supplementary information:

5.5.2.2	TABLE: Stored discharge on capacitors	N/A
---------	---------------------------------------	-----

Supply Voltage (V), Hz	Test Location	Operating Condition (N, S)	Switch position On or off	Measured Voltage (after 2 seconds)	ES Classification

Supplementary information:

X-capacitors installed for testing are:

bleeding resistor rating:

ICX:

Notes:

A. Test Location:

Phase to Neutral; Phase to Phase; Phase to Earth; and/or Neutral to Earth

B. Operating condition abbreviations:

N – Normal operating condition (e.g., normal operation, or open fuse); S –Single fault condition

5.6.6.2	TABLE: Resistance of protective conductors and terminations	N/A
---------	---	-----

Accessible part	Test current (A)	Duration (min)	Voltage drop (V)	Resistance (Ω)

Supplementary information:

5.7.2.2, 5.7.4	TABLE: Earthed accessible conductive part	N/A
----------------	---	-----

Supply voltage..... :	—
Location	Test conditions specified in 6.1 of IEC 60990 or Fault Condition No in IEC 60990 clause 6.2.2.1 through 6.2.2.8, except for 6.2.2.7
	1
	2*
	3
	4
	5
	6
	7
	8

Supplementary Information:

Notes:

[1] Supply voltage is the anticipated maximum Touch Voltage



EN 62368-1

Clause	Requirement + Test	Result - Remark	Verdict
--------	--------------------	-----------------	---------

[2] Earthed neutral conductor [Voltage differences less than 1% or more]
 [3] Specify method used for measurement as described in IEC 60990 sub-clause 4.3
 [4] IEC60990, sub-clause 6.2.2.7, Fault 7 not applicable.
 [5] (*) IEC60990, sub-clause 6.2.2.2 is not applicable if switch or disconnect device (e.g., appliance coupler) provided.

6.2.2 Table: Electrical power sources (PS) measurements for classification P

Source	Description	Measurement	Max Power after 3 s	Max Power after 5 s ^{*)}	PS Classification
A	SD card port (CN8) (Normal)	Power (W) :	5.934	--	PS1
		V _A (V) :	2.58Vdc	--	
		I _A (A) :	2.30	--	
	SD card port (CN8) U17 Pin 1 – 6 Shorted	Power (W) :	0	--	PS1
		V _A (V) :	0Vdc	--	
		I _A (A) :	0	--	
B	SIM card port (SIM) (Normal)	Power (W) :	0	--	PS1
		V _A (V) :	0Vdc	--	
		I _A (A) :	0	--	
C	LAN1 port (CN5) (Normal)	Power (W) :	0	--	PS1
		V _A (V) :	0Vdc	--	
		I _A (A) :	0	--	
D	LAN2 port (CN6) (Normal)	Power (W) :	0	--	PS1
		V _A (V) :	0Vdc	--	
		I _A (A) :	0	--	
E	Console port (CN7) (Normal)	Power (W) :	0	--	PS1
		V _A (V) :	0Vdc	--	
		I _A (A) :	0	--	
F	Isolated DIO port (CN2) (Normal)	Power (W) :	0	--	PS1
		V _A (V) :	0Vdc	--	
		I _A (A) :	0	--	
G	CAN port (CN1) (Normal)	Power (W) :	0	--	PS1
		V _A (V) :	0Vdc	--	
		I _A (A) :	0	--	

Supplementary Information:

(*) Measurement taken only when limits at 3 seconds exceed PS1 limits

(#) Overcurrent protective device operates during the test, the measurement was repeated at 125% of the current rating of the overcurrent protective device.

6.2.3.1 Table: Determination of Potential Ignition Sources (Arcing PIS) N/A

Location	Open circuit voltage After 3 s (V _p)	Measured r.m.s current (I _{rms})	Calculated value (V _p x I _{rms})	Arcing PIS? Yes / No
----------	--	--	---	----------------------



EN 62368-1			
------------	--	--	--

Clause	Requirement + Test	Result - Remark	Verdict
--------	--------------------	-----------------	---------

<p>Supplementary information:</p> <p>An Arcing PIS requires a minimum of 50 V (peak) a.c. or d.c. An Arcing PIS is established when the product of the open circuit voltage (V_p) and normal operating condition rms current (I_{rms}) is greater than 15.</p>			

6.2.3.2	Table: Determination of Potential Ignition Sources (Resistive PIS)	N/A
----------------	---	-----

Circuit Location (x-y)	Operating Condition (Normal / Describe Single Fault)	Measured wattage or VA During first 30 s (W / VA)	Measured wattage or VA After 30 s (W / VA)	Protective Circuit, Regulator, or PTC Operated? Yes / No (Comment)	Resistive PIS? Yes/No

<p>Supplementary Information:</p> <p>A combination of voltmeter, VA and ammeter IA may be used instead of a wattmeter.</p> <p>If a separate voltmeter and ammeter are used, the product of (VA x IA) is used to determine Resistive PIS classification.</p> <p>A Resistive PIS: (a) dissipates more than 15 W, measured after 30 s of normal operation, <u>or</u> (b) under single fault conditions has either a power exceeding 100 W measured immediately after the introduction of the fault if electronic circuits, regulators or PTC devices are used, or has an available power exceeding 15 W measured 30 s after introduction of the fault.</p>					
---	--	--	--	--	--

8.5.5	TABLE: High Pressure Lamp	N/A
--------------	----------------------------------	-----

Description	Values	Energy Source Classification
Lamp type.....:		—
Manufacturer		—
Cat no.:		—
Pressure (cold) (MPa).....:		MS_
Pressure (operating) (MPa)		MS_
Operating time (minutes)		—
Explosion method		—
Max particle length escaping enclosure (mm) .:		MS_
Max particle length beyond 1 m (mm).....:		MS_
Overall result		

Supplementary information:		
----------------------------	--	--

B.2.5	TABLE: Input test	P
--------------	--------------------------	---

U (V)	I (A)	I rated (A)	P (W)	P rated (W)	Fuse No	I fuse (A)	Condition/status
9Vdc	0.60	4	5.4	--	--	--	Maximum normal load. (Supplied by External terminal block)



EN 62368-1							
Clause	Requirement + Test					Result - Remark	Verdict
50Vdc	0.12	4	6.0	--	--	--	Maximum normal load. (Supplied by External terminal block)
Supplementary information: Maximum normal load refer to Additional application considerations.							

B.3		TABLE: Abnormal operating condition tests						P
Ambient temperature (°C)							23, if not specified.	—
Power source for EUT: Manufacturer, model/type, output rating ..							--	—
Component No.	Abnormal Condition	Supply voltage, (V)	Test time (ms)	Fuse no.	Fuse current (A)	T-couple	Temp. (°C)	Observation
USB port (CN4)	Overload	9/50Vdc	1hr	--	--	--	--	Output voltage: 5.0Vdc, Maximum available current: 1.4A, No hazard, No damage.
	Shorted	9/50Vdc	30min	--	--	--	--	Unit USB port shutdown, No hazard, No damage
SD card port (CN8)	Overload	9/50Vdc	1hr	--	--	--	--	Output voltage: 3.3Vdc, Maximum available current: 2A, No hazard, No damage.
	Shorted	9/50Vdc	30min	--	--	--	--	No hazard, No damage
SIM card port (SIM)	Overload	9/50Vdc	30 mins	--	--	--	--	Output voltage: 0Vdc, Maximum available current: 0A, No hazard, No damage
	Shorted	9/50Vdc	30min	--	--	--	--	No hazard, No damage
LAN1 port (CN5)	Overload	9/50Vdc	30 mins	--	--	--	--	Output voltage: 0Vdc, Maximum available current: 0A, No hazard, No damage
	Shorted	9/50Vdc	30 mins	--	--	--	--	No hazard, No damage
LAN1 port (CN5)	Overload	9/50Vdc	1hr	--	--	--	--	Output voltage: 0Vdc, Maximum available current: 0A, No hazard, No damage



EN 62368-1

Clause	Requirement + Test		Result - Remark					Verdict
	Shorted	9/50Vdc	30 mins	--	--	--	--	No hazard, No damage
LAN2 port (CN6)	Overload	9/50Vdc	1hr	--	--	--	--	Output voltage: 0Vdc, Maximum available current: 0A, No hazard, No damage.
	Shorted	9/50Vdc	30 mins	--	--	--	--	No hazard, No damage
Console port (CN7)	Overload	9/50Vdc	30 mins	--	--	--	--	Output voltage: 0Vdc, Maximum available current: 0A, No hazard, No damage.
	Shorted	9/50Vdc	30 mins	--	--	--	--	No hazard, No damage
Isolated DIO port (CN2)	Overload	9/50Vdc	1 hr	--	--	--	--	Output voltage: 5.11Vdc, Maximum available current: 0.08A, No hazard, No damage.
	Shorted	9/50Vdc	30 mins	--	--	--	--	Unit RS485 port shutdown, No hazard, No damage

Supplementary information:

Test table is provided to record abnormal and fault conditions for all applicable energy sources including Thermal burn injury. Column "Abnormal/Fault." Specify if test condition by indicating "Abnormal" then the condition for a Clause B.3 test or "Single Fault" then the condition for Clause B.4.

B.4		TABLE: Fault condition tests							P
Ambient temperature (°C)						23, if not specified.		—	
Power source for EUT: Manufacturer, model/type, output rating						--		—	
Component No.	Fault Condition	Supply voltage, (V)	Test time (ms)	Fuse no.	Fuse current, (A)	T-couple	Temp. (°C)	Observation	
U15 Pin 29 – 32	Shorted	9/50Vdc	30 mins	--	--	--	--	Unit shutdown, No hazard, No damage.	
U15 Pin 25 – 29	Shorted	9/50Vdc	30 mins	--	--	--	--	Unit shutdown, No hazard, No damage.	
U8 Pin 2 – 6	Shorted	9/50Vdc	30 mins	--	--	--	--	Unit shutdown, No hazard, No damage.	

Supplementary information:

EN 62368-1

Clause	Requirement + Test	Result - Remark	Verdict
--------	--------------------	-----------------	---------

Annex M	TABLE: Batteries		P
----------------	-------------------------	--	----------

The tests of Annex M are applicable only when appropriate battery data is not available

P

Is it possible to install the battery in a reverse polarity position?

The RTC battery connector is designed so that the polarity cannot be reversed.

N/A

	Non-rechargeable batteries			Rechargeable batteries					
	Discharging		Un-intentional charging	Charging		Discharging		Reversed charging	
	Meas. current	Manuf. Specs.		Meas. current	Manuf. Specs.	Meas. current	Manuf. Specs.	Meas. current	Manuf. Specs.

For RTC battery (BAT1)

Max. current during fault condition (D5) Pin 1 – 2 Shorted	--	--	3.2mA	--	--	--	--	--	--
Max. current during fault condition (R86) Shorted	--	--	0A	--	--	--	--	--	--

Test results: See below. Verdict

- Chemical leaks	No chemical leaks.	P
- Explosion of the battery	No explosion of the battery.	P
- Emission of flame or expulsion of molten metal	No such conditions.	P
- Electric strength tests of equipment after completion of tests	Only functional insulation inside the EUT.	N/A

Supplementary information:

The RTC battery is protected by the diode (D5) in series with a resistor (R86) 1k ohm.

The maximum charging current refer to table 4.1.2.

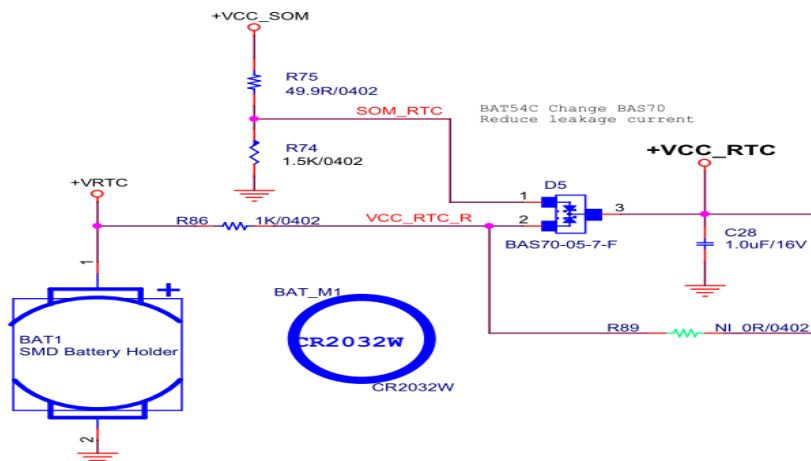



EN 62368-1

Clause	Requirement + Test	Result - Remark	Verdict
--------	--------------------	-----------------	---------

Annex M.4	Table: Additional safeguards for equipment containing secondary lithium batteries		N/A
------------------	--	--	-----

Battery/Cell No.	Test conditions	Measurements			Observation
		U	I (A)	Temp (C)	
	Normal				
	Abnormal				
	Single fault –SC/OC				

Supplementary Information:

Battery identification	Charging at T_{lowest} (°C)	Observation	Charging at $T_{highest}$ (°C)	Observation

Supplementary Information:

Annex Q.1	TABLE: Circuits intended for interconnection with building wiring (LPS)	P
------------------	--	---

Note: Measured UOC (V) with all load circuits disconnected: See below.

Output Circuit	Components	U _{oc} (V)	I _{sc} (A)		S (VA)	
			Meas.	Limit	Meas.	Limit
SD card port (CN8)	Normal	3.30Vdc	2.3	≤ 8.0	5.934 (2.58Vdc x 2.3A)	≤ 100
	U17 Pin 1 – 9 SC	0Vdc	0	≤ 8.0	0	≤ 100
SIM card port (SIM)	Normal	0Vdc	0	≤ 8.0	0	≤ 100
LAN1 port (CN5)	Normal	0Vdc	0	≤ 8.0	0	≤ 100
LAN2 port (CN6)	Normal	0Vdc	0	≤ 8.0	0	≤ 100
Console port (CN7)	Normal	5.11Vdc	0.1	≤ 8.0	0.50 (5.04Vdc x 0.1A)	≤ 100
Isolated DIO port (CN2)	Normal	5.11Vdc	0.1	≤ 8.0	0.50 (5.04Vdc x 0.1A)	≤ 100
CAN port (CN1)	Normal	0Vdc	0	≤ 8.0	0	≤ 100

Supplementary Information:

SC=Short circuit, OC=Open circuit



EN 62368-1			
Clause	Requirement + Test	Result - Remark	Verdict

T.2, T.3, T.4, T.5	TABLE: Steady force test					P
Part/Location	Material	Thickness (mm)	Force (N)	Test Duration (sec)	Observation	
Internal components	--	--	10	5	1)	
Supplementary information: 1) No cracking, class 3 energy sources did not become accessible and all safeguards remain effective.						

T.6, T.9	TABLE: Impact tests				N/A
Part/Location	Material	Thickness (mm)	Vertical distance (mm)	Observation	
Supplementary information:					

T.7	TABLE: Drop tests				N/A
Part/Location	Material	Thickness (mm)	Drop Height (mm)	Observation	
Supplementary information:					

T.8	TABLE: Stress relief test					N/A
Part/Location	Material	Thickness (mm)	Oven Temperature (°C)	Duration (h)	Observation	
Supplementary information:						

Photos:

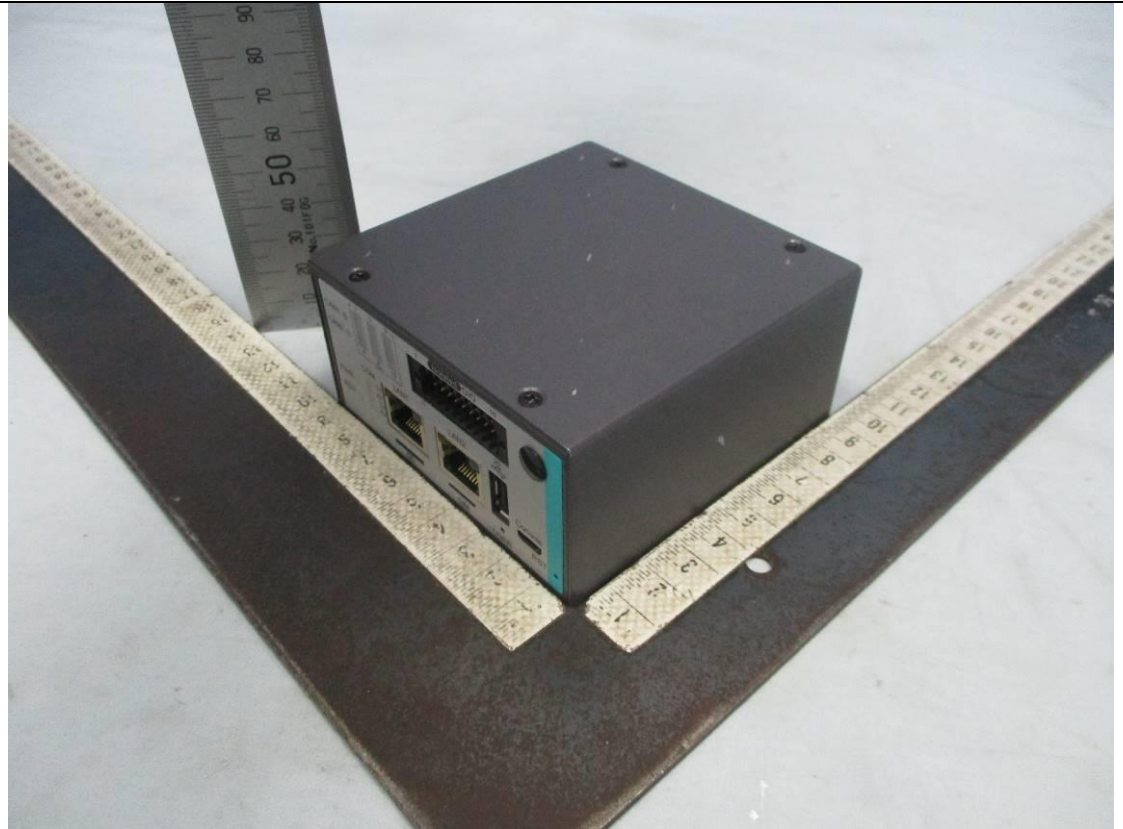

General view-1

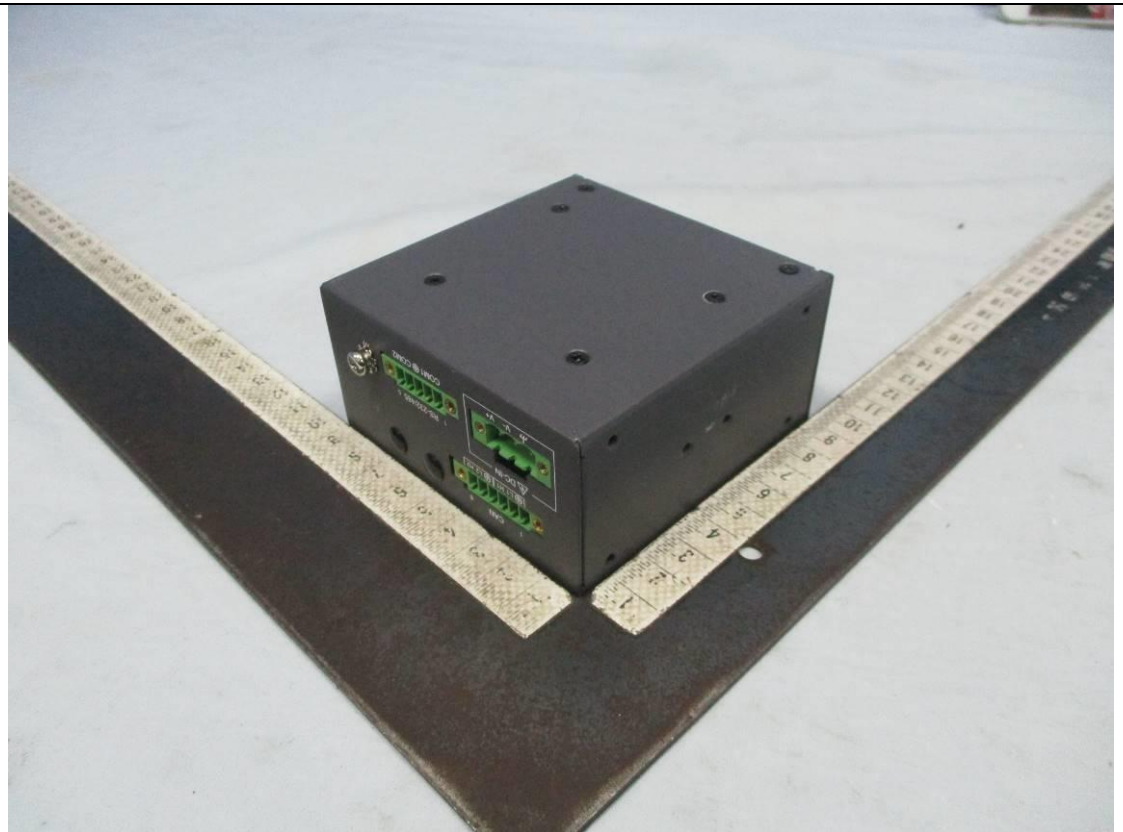

General view-2



General view-3



General view-4



Internal view-1

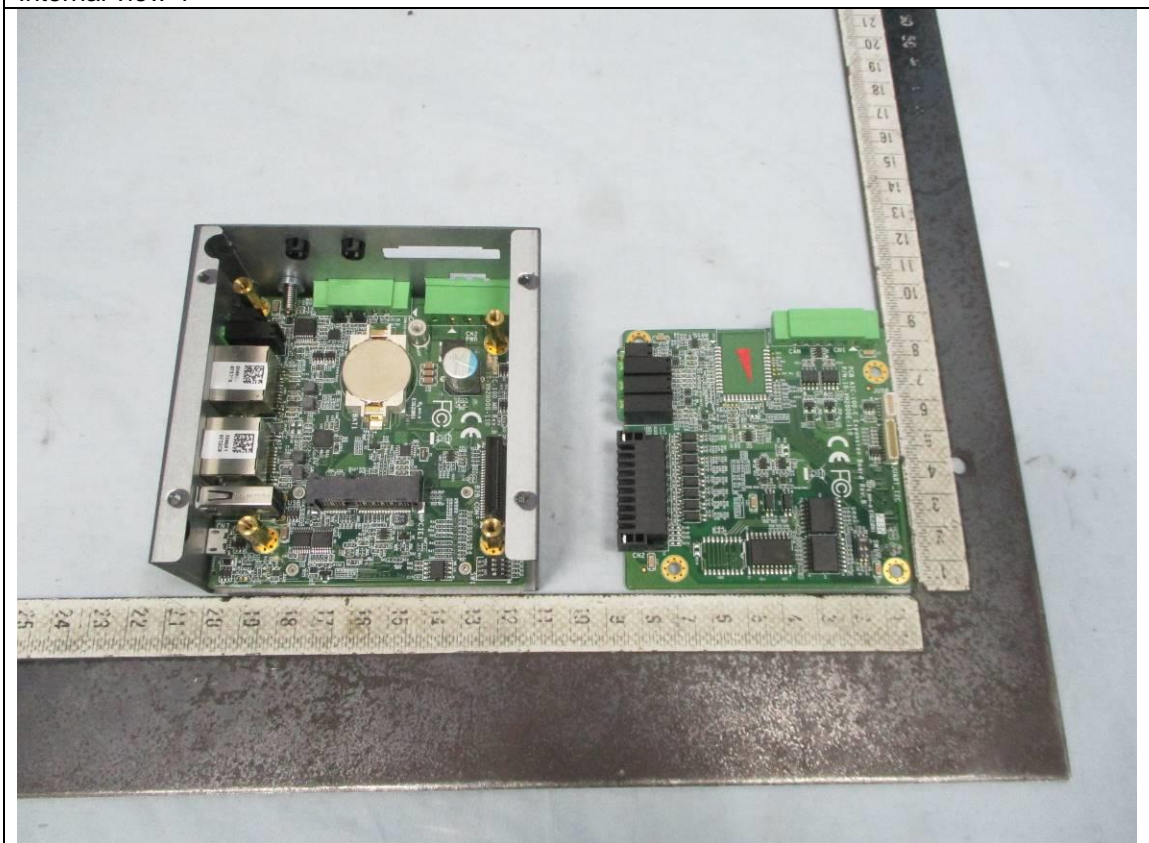

Internal view-2

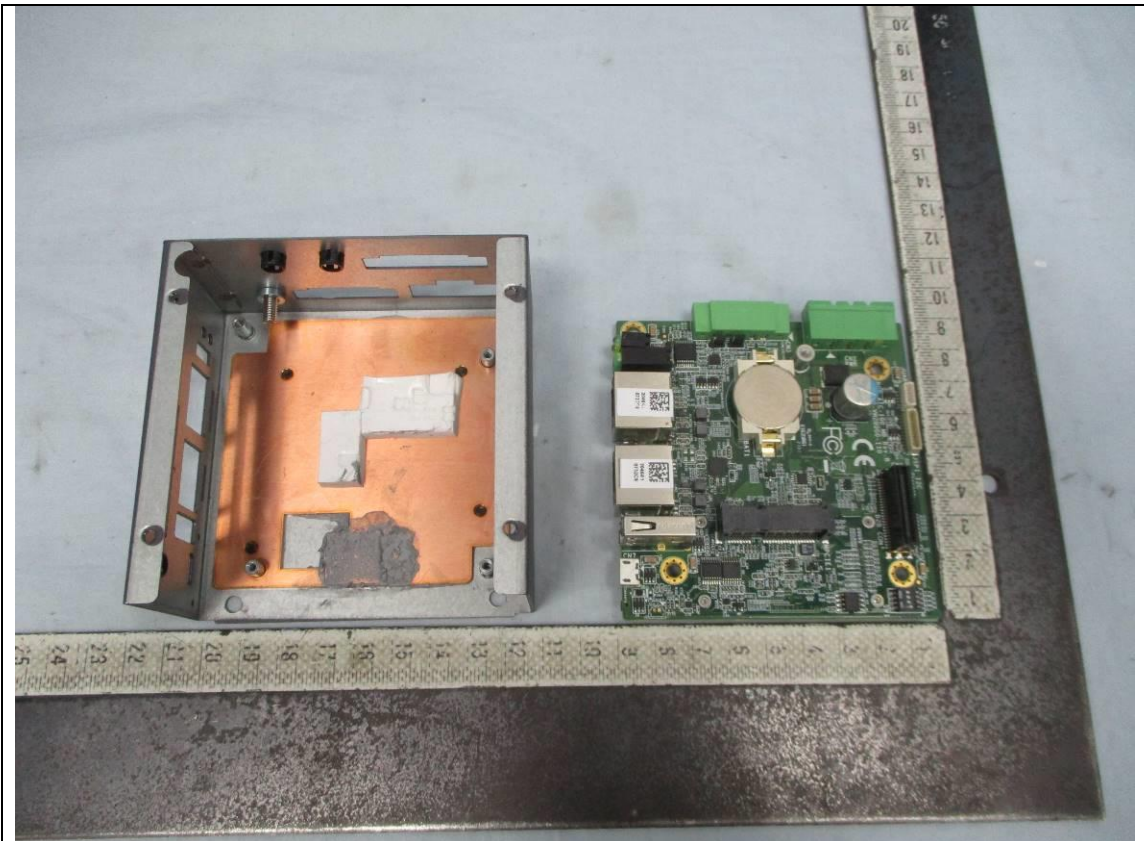

Internal view-3



Top side view of Isolated board

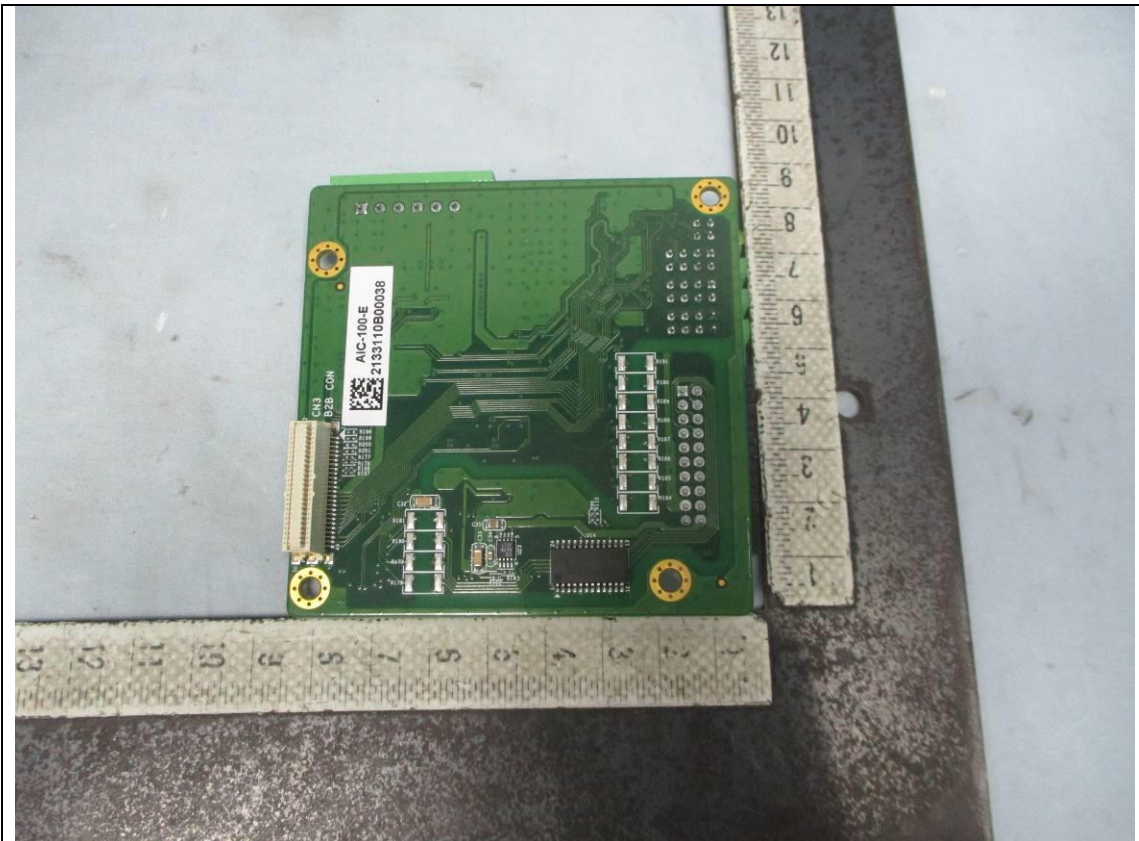

Bottom side view of Isolated board



Top side view of RTC battery board



Bottom side view of RTC battery board

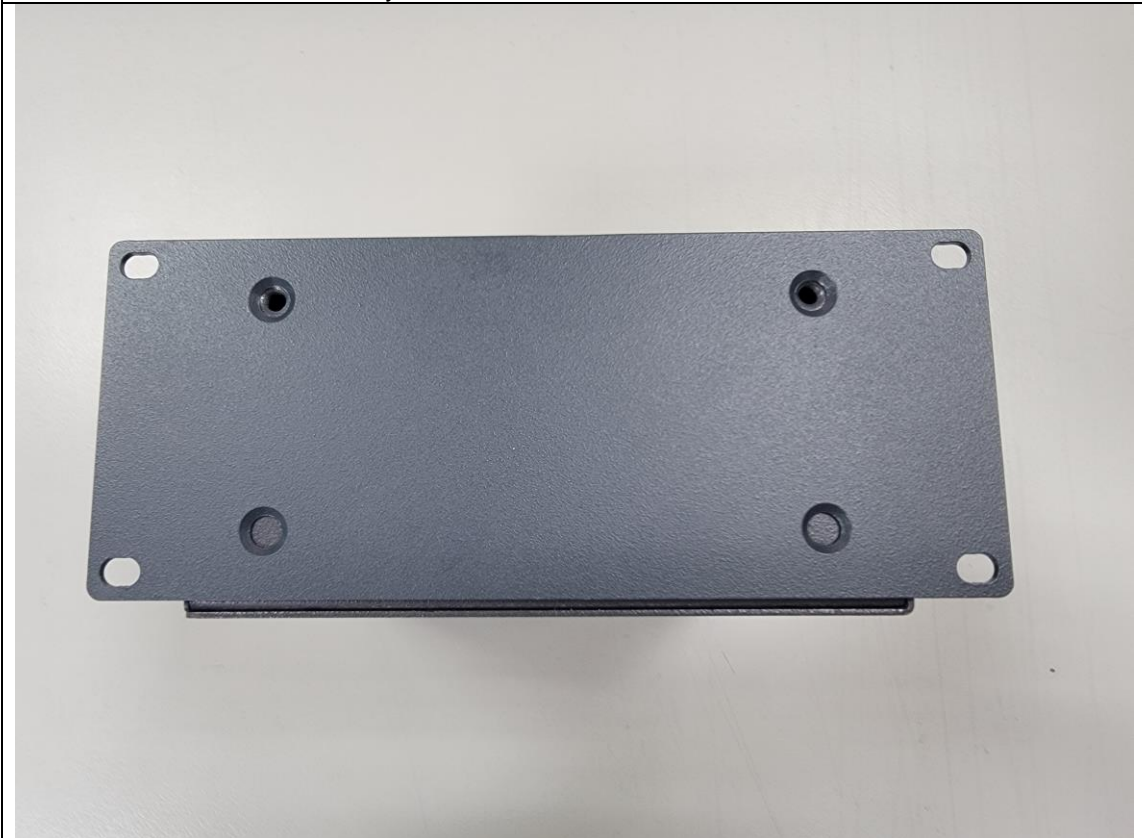

Wall-mounted sheet metal